

Mastertech
7120G

型式名 7120G-2

クローラクレーン

最大定格総荷重 120t×5.0m

▶主要諸元	1
▶フック巻上限界	1
▶仕様とアタッチメント	1
クローラクレーン	
▶全体図	2
▶ブーム構成	3
▶ロングブーム構成/ジブ構成	4
▶作動範囲図	5, 6
▶定格総荷重	7
▶主ブーム/補助シーブ定格総荷重表	9~11
▶ロング主ブーム定格総荷重表	11
▶ロング補助シーブ定格総荷重表	12
▶ジブ定格総荷重表	13~16
▶主ブーム定格総荷重表 (45.1tカウンタウエイト)(オプション)	17
▶補助シーブ定格総荷重表 (45.1tカウンタウエイト)(オプション)	17~19
ラフティングタワー	
▶全体図	20
▶タワー構成	21
▶タワージブ構成	21
▶定格総荷重	22
▶タワー長さ30.4m	23
▶タワー長さ33.4m	24
▶タワー長さ36.5m	25
▶タワー長さ39.5m	26
▶タワー長さ42.5m	27
▶タワー長さ45.6m	28
▶タワー長さ48.6m	29
▶タワー長さ51.7m	30
アタッチメント (オプション)	
▶コラムセル (45.1tカウンタウエイト)	31
台船搭載 (オプション)	
▶主ブーム/コラムセル作業定格総荷重表	32
▶分解時の寸法・質量	33~42
▶標準装備品/オプション装備品	43

▶主要諸元 (型式：7120G-2)

項目	仕様	仕様	
		クローラクレーン	ラフティングタワー
最大つり上げ能力	t×m	120×5.0	20×15.0
ブーム(タワー)長さ	m	15.2~61.0	30.4~51.7
		61.0~79.2(ロング)	
ジブ(タワージブ)長さ	m	12.2~30.5	22.9~44.2
最大ブーム(タワー)+ジブ(タワージブ)長さ	m	61.0+30.5	51.7+44.2
ロープ速度	主巻	巻上・巻下 m/min	*120~3
	補巻	巻上・巻下 m/min	*120~3
	タワージブ起伏	巻上・巻下 m/min	-
	サード(オプション)	巻上・巻下 m/min	*110~3
	ブーム(タワー)起伏	巻上・巻下 m/min	*48~2
旋回速度	min ⁻¹ {rpm}	2.1{2.1}	
走行速度	km/h	*1.3/0.9	
作業時質量(基本姿勢)	t	123	133
接地圧(基本姿勢)	kPa{kkgf/cm ² }	96{0.98}	104{1.06}
登坂能力(tanθ)	%(度)	30(16.7)	-
定格ラインプル	kN{tf}	118{12.0}	-
エンジン	名称	日野P11C-VN	
	定格出力	kW/min ⁻¹ 271/1,850	
ワイヤロープ	主巻	mm	φ26
	補巻(タワージブ)	mm	φ26
	ブーム(タワー)	mm	φ20

サードドラムはオプションです。

各ロープ速度はドラム1層目での値です。

*印の速度は軽負荷の時の値であり、負荷により速度の変動があります。

単位は国際単位系のS I単位で、{ }内は従来表示です。

▶フック巻上限界 (単位:m)

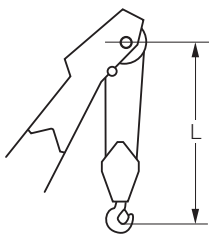

使用フック	L
120 tフック	5.0
70 tフック	5.0
35 tフック	5.0

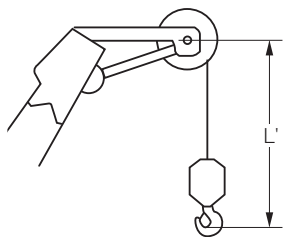

使用フック	L'
ボールフック	4.2

▶仕様とアタッチメント (クローラクレーン/ラフティングタワー)

アタッチメント	仕様	
	クローラクレーン	ラフティングタワー
4.6m上部ブーム	◎	-
3.0m中間テーパーブーム*1	◎	-
1.4mタワーキャップ	-	◎
7.6m下部ブーム(共用)	◎	
3.0m中間ブーム(ケーブルローラ付・共用)	○	◎
6.1m中間ブーム(ケーブルローラ付・共用)	○	
9.1m中間ブーム(ケーブルローラ付・共用)*2	○	◎
9.1mタワー専用中間ブーム	○兼用可	◎
4.6m上部ジブ	○	-
4.6m下部ジブ	○	-
3.1m中間ジブ	○	-
6.0m中間ジブ	○	-
7.6m上部タワージブ*3	△	◎
6.1m下部タワージブ	-	◎
3.0m中継ジブ*4	△	◎
3.0m中間タワージブ*5	△	◎
6.1m中間タワージブ*5	△	◎
9.1m中間タワージブ*5	△	○
120tフック(5枚シーブ)	◎	-
70tフック(3枚シーブ)	○	-
35tフック(1枚シーブ)	○	◎
ボールフック	○	
補助シーブ	○	-
主巻ワイヤロープ(φ26×275m)	◎	-
補巻ワイヤロープ(φ26×255m)	○	-
ブーム(タワー)起伏ワイヤロープ(φ20×190m)	◎	◎
タワー主巻ワイヤロープ(φ26×290m)	-	◎
タワージブ起伏ワイヤロープ(φ26×145m)	-	◎
タワーブーム起伏ワイヤロープ(φ20×190m)	-	◎

◎印は標準仕様、○印はオプション設定を示します。

△印はロングブームを構成する場合に必要となるアタッチメントを示します。

*1 クローラクレーンの上部ブームまたはロングブームとセットで使用します。

*2 クローラクレーンの中間ブームに転用できます。

*3 ロングブーム仕様では上部ブームとして使用します。

*4 ロングブーム仕様では3.0mテーパーブームと、ラフティングタワーでは下部タワージブとセットで使用します。

*5 ロングブーム仕様で中間ブームとして使用します。

クローラクレーン



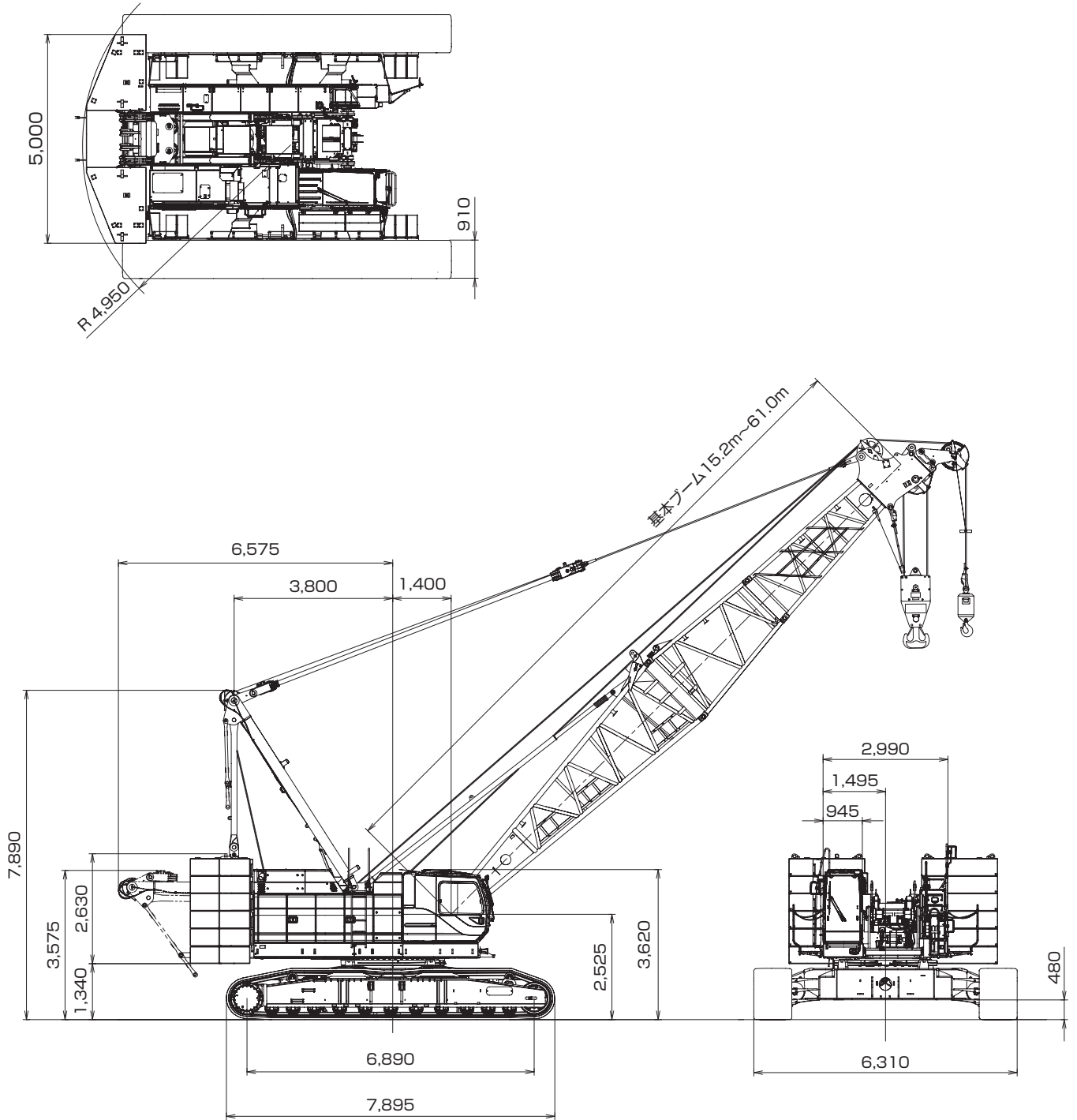

全体図(単位: mm)





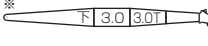
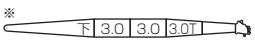
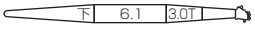
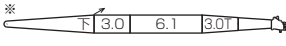
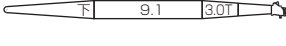
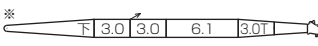
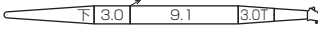
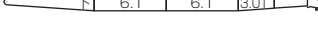
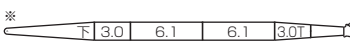

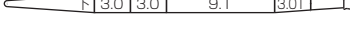

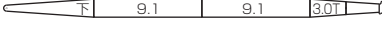
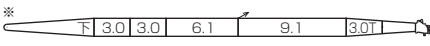
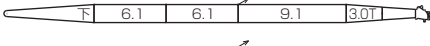
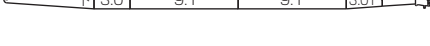
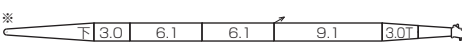
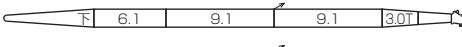
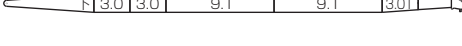
▶ブーム構成

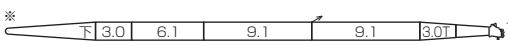
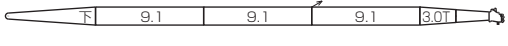
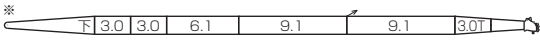
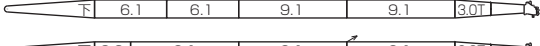
- ↗印は、ジブ使用時のガイドライン取付位置を示します。
- ※印は、これより短いブームの組立可能な構成を示します。
- 使用するガイドラインの径はφ30mmです。

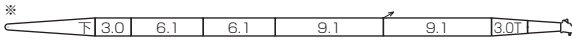
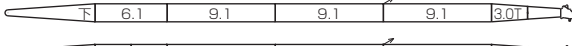
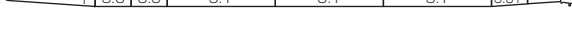
中間ブームの種類		
記号	ブーム長さ	備考
3.0	3.0m	ブーム
6.1	6.1m	ブーム
9.1	9.1m	ブーム
3.0T	3.0m	テーパブーム
3.0A	3.0m	中継ジブ
3.0	3.0m	タワージブ
6.1	6.1m	タワージブ
9.1	9.1m	タワージブ

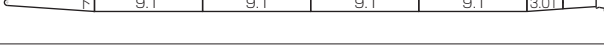
ブーム長さ m (ft.)	ブーム構成
15.2 (50)	
18.3 (60)	* 
21.3 (70)	*  * 
24.4 (80)	*  * 
27.4 (90)	*  *  * 
30.5 (100)	*  *  * 
33.5 (110)	*  * 
36.6 (120)	*  *  * 
39.6 (130)	*  *  * 

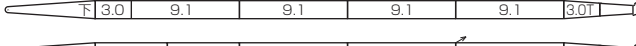
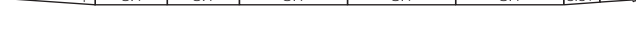
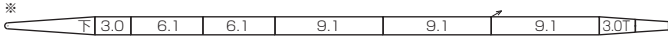
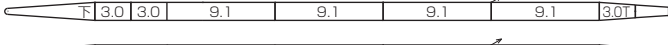
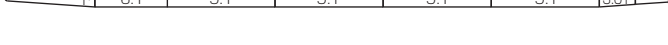
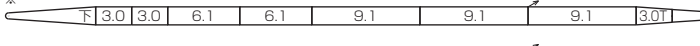
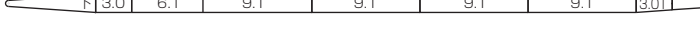
ブーム長さ m (ft.)	ブーム構成
42.7 (140)	*  * 
45.7 (150)	*  *  * 
48.8 (160)	*  *  * 
51.8 (170)	*  * 
54.9 (180)	*  *  * 
57.9 (190)	*  *  * 
61.0 (200)	*  * 

▶ロングブーム構成

- ※印は、これより短いブームの組立可能な構成を示します。
- 使用するガイラインの径はφ30mmです。

ブーム長さ m (ft.)	ブーム構成/ロング
61.0 (200)	
64.0 (210)	*
67.1 (220)	*
70.1 (230)	
73.2 (240)	*
76.2 (250)	
79.2 (260)	

▶ジブ構成

- ジブを装着できる主ブームの長さは、24.4m (80) ~ 61.0m (200) です。

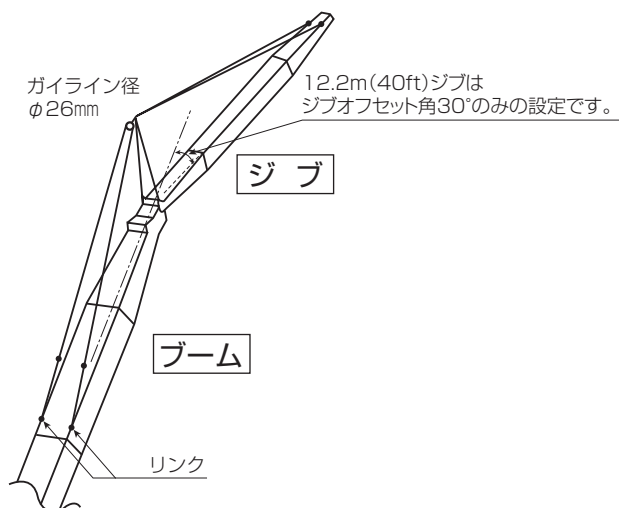

ジブ長さ m (ft.)	ジブ構成	オフセット角
12.2 (40)		30°
18.3 (60)		10°/30°
24.4 (80)		10°/30°
30.5 (100)		10°/30°

▶作動範囲図
 ■主ブーム

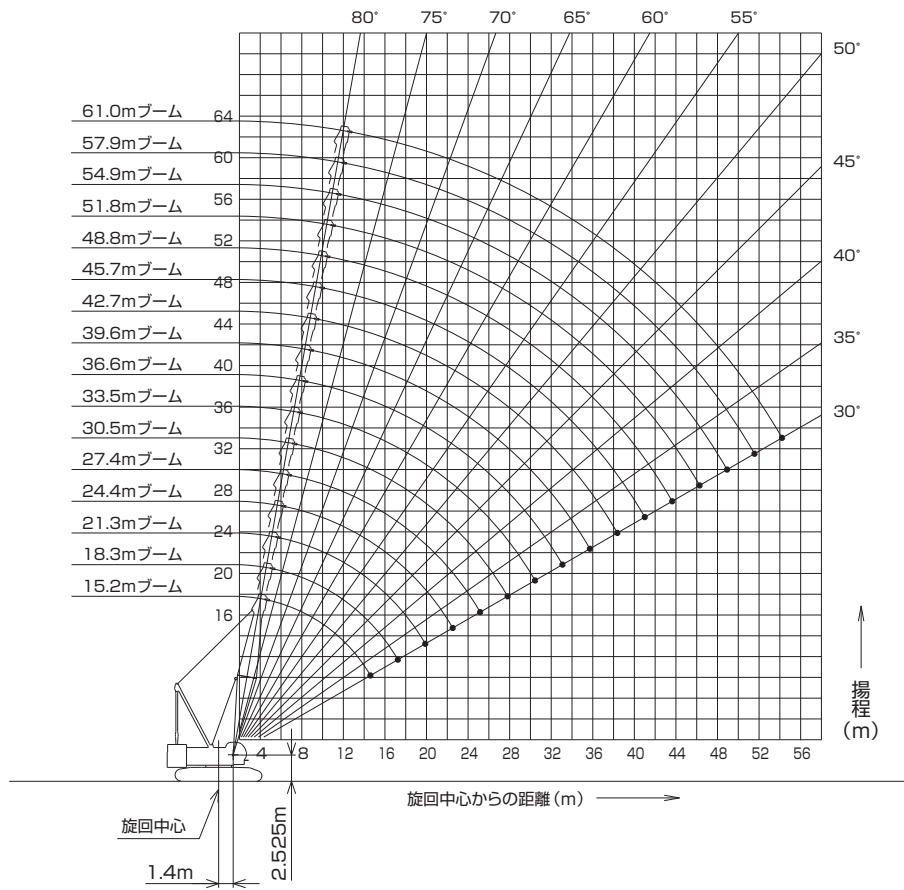

▶ロングブーム

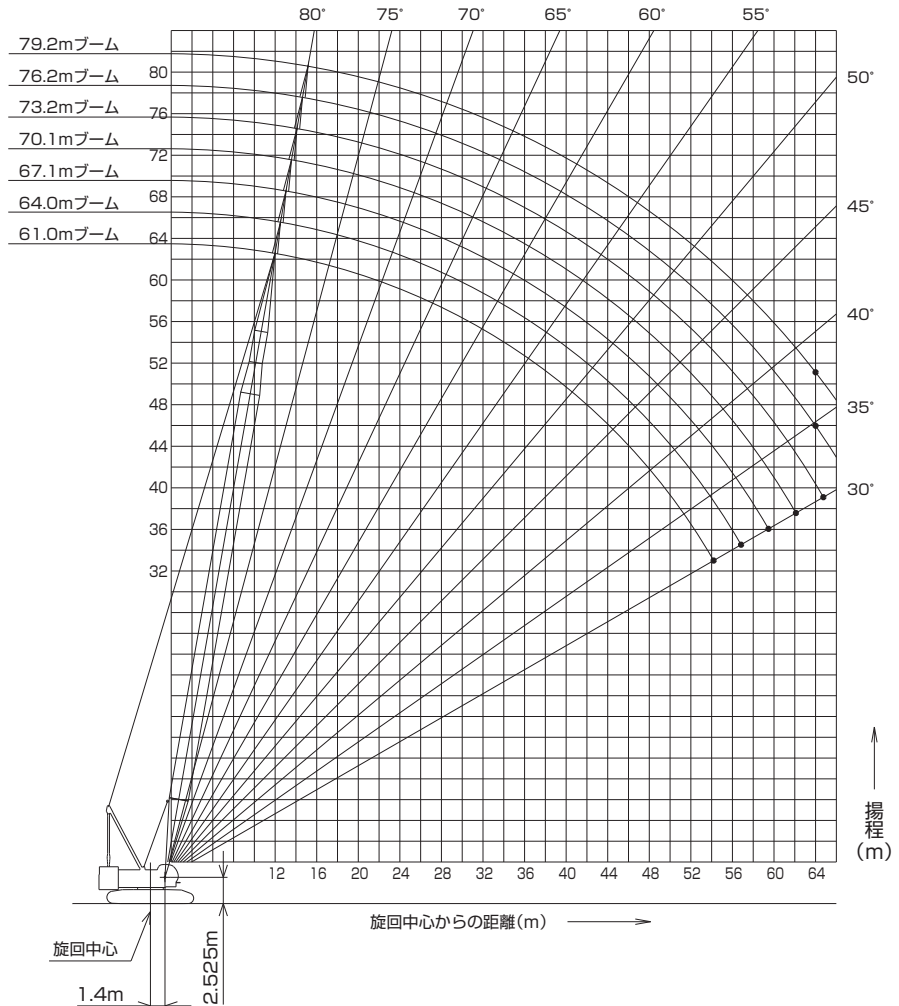

▣ジブ装着
 (オフセット角度10°/30°)

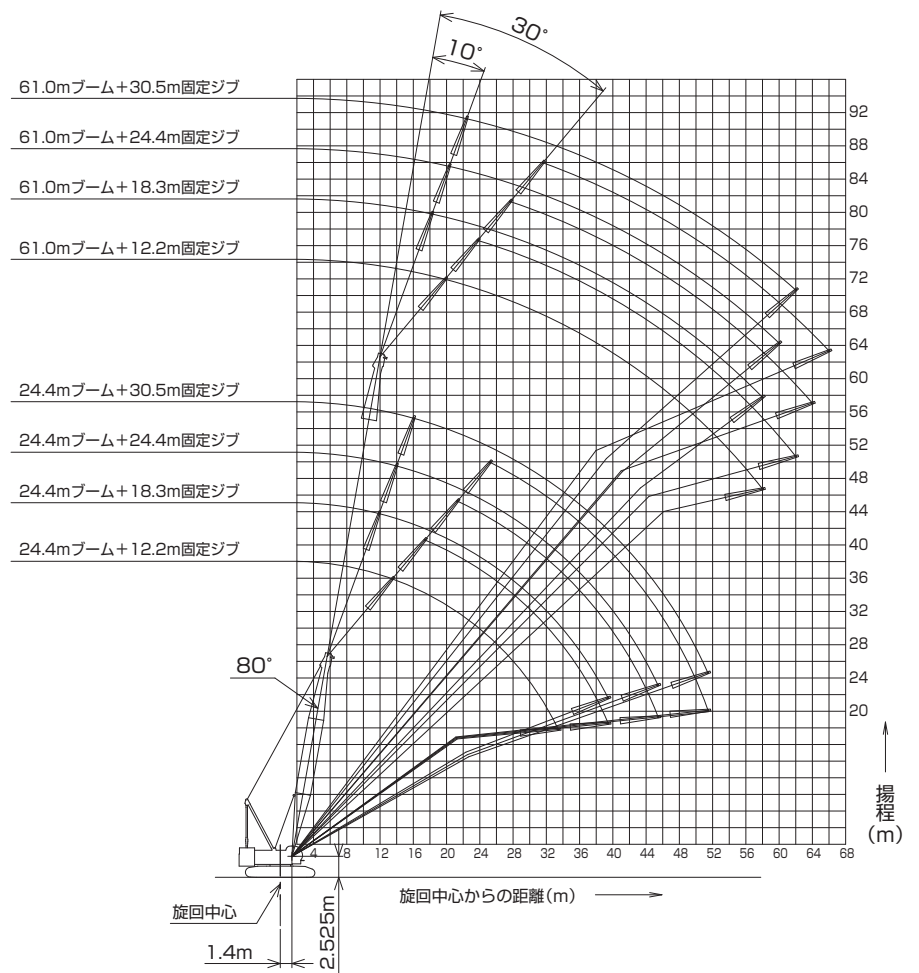

▶ 定格総荷重

- 定格総荷重とは、水平堅土上における転倒荷重の78%以内で、フックブロック、玉掛用ワイヤロープ等のつり具の質量を含んだ値です。
- 作業半径とはクレーン旋回中心よりつり上荷重の重心までの水平距離を意味します。
- 実際につり上げ得る荷重は定格総荷重から（フック＋玉掛用ワイヤロープ等のつり具）の質量を差し引いた値になります。

巻上げロープ巻掛本数に対する最大巻上荷重とフックの質量

フック 呼称	最大巻上荷重(t)										フック 質量
	1本掛	2本掛	3本掛	4本掛	5本掛	6本掛	7本掛	8本掛	9本掛	10本掛	
120t	-	-	-	48.0	60.0	72.0	84.0	96.0	108.0	120.0	1.70t
70t	-	24.0	36.0	48.0	60.0	70.0	-	-	-	-	1.20t
35t	-	24.0	35.0	-	-	-	-	-	-	-	0.90t
ボール フック	12.0	-	-	-	-	-	-	-	-	-	0.45t

ただし、中間ブームにブームネスティングローラ（オプション）が取付いた状態で作業する場合の定格荷重の最大値は、使用するフックの呼称容量から使用するフック質量とブームネスティングローラ質量（下表）を差し引いた値とします。

主ブーム

ブーム長さ(m)	15.2	18.3	21.3	24.4	27.4	30.5	33.5	36.6
差し引く値(t)	0.0	0.0	0.1	0.1	0.1	0.1	0.1	0.1

ブーム長さ(m)	39.6	42.7	45.7	48.8	51.8	54.9	57.9	61.0
差し引く値(t)	0.1	0.1	0.2	0.2	0.2	0.2	0.2	0.2

ロング主ブーム

ブーム長さ(m)	61.0	64.0	67.1	70.1	73.2	76.2	79.2
差し引く値(t)	0.2	0.2	0.2	0.2	0.2	0.2	0.2

- 定格総荷重をつる場合にも風の影響、地盤の状態、作業速度その他安全作業に有害な状況がある時はオペレータは荷重の軽減、作業速度を遅くするなど状況に応じた判断をする責任があります。
- 表中の空欄の個所では作業を行うことができません。
- クレーン作業中には必ずガントリを最高位置に立ててください。
- すべてのブーム（ジブ）長さにおける中間ブーム（ジブ）の構成は取扱説明書の指示を厳守してください。
- 主ブームに補助シーブを取り付けたままで主フックを使用する場合の定格総荷重は、主ブーム定格総荷重から、一律0.8t差し引いた値となります。ただし最小定格総荷重は2.0tとします。
- 補助シーブを装着できる主ブーム長さは、15.2m（50）～61.0m（200）です。
- 補助シーブを装着できるロングブーム長さは61.0m（200）～76.2m（250）です。
- ジブを装着できる主ブーム長さは、24.4m（80）～61.0m（200）です。

⚠ 操作ミスなどによるつり荷の落下を防ぐため、クレーン作業では自由降下（フリーフォール）作業は行わないでください。

【カウンタウエイト減量時】

- 自立可能な最長ブーム長さは、カウンタウエイト段数5段（最上段から1段減量）で、61.0mです。
- カウンタウエイト減量時、ジブ付仕様の設定はありません。
- 補助シーブを装着できる主ブーム長さは、カウンタウエイト段数5段（最上段から1段減量）で15.2m～61.0mです。



主ブーム定格総荷重表

(単位:t)

ブーム長さ 作業半径(m)	15.2	18.3	21.3	24.4	27.4	30.5	33.5	36.6	39.6	42.7	45.7	48.8	51.8	54.9	57.9	61.0	ブーム長さ 作業半径(m)	
4.5	120.0/4.5m																4.5	
5.0	120.0	108.0/5.1m	96.0/5.6m														5.0	
6.0	100.0	99.8	94.9	84.0/6.1m	74.6/6.7m												6.0	
7.0	85.7	85.5	85.3	81.5	73.7	66.4/7.2m	59.4/7.7m										7.0	
8.0	73.7	73.6	73.5	73.5	71.3	64.7	58.9	53.6/8.2m	48.0/8.8m								8.0	
9.0	61.5	61.3	61.2	61.1	61.0	60.9	57.2	52.5	48.0	43.5/9.3m	39.6/9.8m						9.0	
10.0	52.6	52.5	52.3	52.2	52.1	52.0	52.0	51.2	46.8	42.8	39.5	36.0/10.4m	32.1/10.9m	29.4/11.4m			10.0	
12.0	40.6	40.5	40.3	40.2	40.0	40.0	39.9	39.7	39.7	39.5	37.8	34.7	31.4	29.0	26.9	24.0/12.5m	12.0	
14.0	33.0	32.8	32.6	32.5	32.3	32.3	32.2	32.0	31.9	31.8	31.6	31.6	30.1	27.9	25.9	23.5	14.0	
16.0	29.1/14.9m	27.5	27.3	27.2	26.9	26.9	26.8	26.6	26.5	26.4	26.2	26.1	26.0	25.8	24.9	22.8	16.0	
18.0		24.5/17.5m	23.3	23.2	23.0	22.9	22.8	22.6	22.5	22.4	22.2	22.1	22.0	21.8	21.6	21.4	18.0	
20.0			20.3	20.2	20.0	19.9	19.8	19.5	19.5	19.3	19.1	19.1	18.9	18.7	18.6	18.5	20.0	
22.0			20.2/20.1m	17.8	17.6	17.5	17.4	17.1	17.1	16.9	16.7	16.6	16.5	16.3	16.1	16.0	22.0	
24.0				17.1/22.8m	15.6	15.5	15.4	15.2	15.1	14.9	14.7	14.7	14.5	14.3	14.1	14.1	24.0	
26.0					14.5/26.4m	13.9	13.8	13.6	13.5	13.3	13.1	13.0	12.9	12.7	12.5	12.4	26.0	
28.0						12.6	12.5	12.2	12.1	12.0	11.7	11.7	11.5	11.3	11.1	11.0	28.0	
30.0							11.3	11.1	11.0	10.8	10.6	10.5	10.3	10.1	10.0	9.9	30.0	
32.0								11.0/30.7m	10.1	10.0	9.8	9.6	9.5	9.3	9.1	9.0	32.0	
34.0									9.5/33.3m	9.1	8.9	8.7	8.6	8.5	8.2	8.1	34.0	
36.0										8.4	8.2	8.0	7.9	7.7	7.5	7.3	36.0	
38.0											7.5	7.3	7.2	7.0	6.8	6.6	38.0	
40.0											7.4/38.6m	6.7	6.6	6.4	6.2	6.0	40.0	
42.0												6.4/41.2m	6.1	5.9	5.7	5.5	42.0	
44.0													5.6/43.9m	5.4	5.2	5.0	44.0	
46.0														5.0	4.7	4.6	46.0	
48.0														4.9/46.5m	4.3	4.1	48.0	
50.0															4.1/49.2m	3.7	50.0	
52.0																3.3/51.8m	3.1	52.0
54.0																	2.7	54.0
56.0																2.7/54.4m	56.0	

※表中の太線で囲まれた部分は、ブーム等の強度によって定められた値です。

補助シーブ定格総荷重表 (120tフック装着)

(単位:t)

ブーム長さ 作業半径(m)	15.2	18.3	21.3	24.4	27.4	30.5	33.5	36.6	39.6	42.7	45.7	48.8	51.8	54.9	57.9	61.0	ブーム長さ 作業半径(m)
5.0	12.0/5.3m	12.0/5.8m															5.0
6.0	12.0	12.0	12.0/6.3m	12.0/6.9m													6.0
7.0	12.0	12.0	12.0	12.0	12.0/7.4m	12.0/7.9m											7.0
8.0	12.0	12.0	12.0	12.0	12.0	12.0	12.0	12.0/8.4m									8.0
9.0	12.0	12.0	12.0	12.0	12.0	12.0	12.0	12.0	12.0/9.0m	12.0/9.5m							9.0
10.0	12.0	12.0	12.0	12.0	12.0	12.0	12.0	12.0	12.0	12.0	12.0/10.6m	12.0/11.1m	12.0/11.6m				10.0
12.0	12.0	12.0	12.0	12.0	12.0	12.0	12.0	12.0	12.0	12.0	12.0	12.0	12.0	12.0/12.2m	12.0/12.7m	12.0/13.2m	12.0
14.0	12.0	12.0	12.0	12.0	12.0	12.0	12.0	12.0	12.0	12.0	12.0	12.0	12.0	12.0	12.0	12.0	14.0
16.0	12.0	12.0	12.0	12.0	12.0	12.0	12.0	12.0	12.0	12.0	12.0	12.0	12.0	12.0	12.0	12.0	16.0
18.0	12.0/16.2m	12.0	12.0	12.0	12.0	12.0	12.0	12.0	12.0	12.0	12.0	12.0	12.0	12.0	12.0	12.0	18.0
20.0		12.0/18.8m	12.0	12.0	12.0	12.0	12.0	12.0	12.0	12.0	12.0	12.0	12.0	12.0	12.0	12.0	20.0
22.0			12.0/21.5m	12.0	12.0	12.0	12.0	12.0	12.0	12.0	12.0	12.0	12.0	12.0	12.0	12.0	22.0
24.0				12.0	12.0	12.0	12.0	12.0	12.0	12.0	12.0	12.0	12.0	12.0	12.0	12.0	24.0
26.0				12.0/24.1m	12.0	11.9	11.8	11.6	11.5	11.3	11.1	11.0	10.9	10.7	10.5	10.4	26.0
28.0					11.5/26.7m	10.6	10.5	10.2	10.1	10.0	9.7	9.7	9.5	9.3	9.1	9.0	28.0
30.0						9.7/29.4m	9.3	9.1	9.0	8.8	8.6	8.5	8.3	8.1	8.0	7.9	30.0
32.0							8.4	8.1	8.0	7.8	7.6	7.5	7.3	7.1	7.0	6.9	32.0
34.0								7.2	7.1	6.9	6.7	6.6	6.5	6.2	6.1	6.0	34.0
36.0									6.9/34.7m	6.4	6.2	6.0	5.9	5.7	5.5	5.2	36.0
38.0										5.9/37.3m	5.5	5.3	5.2	5.0	4.8	4.5	38.0
40.0											5.2/39.9m	4.7	4.6	4.4	4.2	3.9	40.0
42.0												4.2	4.1	3.9	3.7	3.4	42.0
44.0												4.1/42.6m	3.6	3.4	3.2	2.9	44.0
46.0													3.3/45.2m	3.0	2.7	2.4	46.0
48.0														2.6/47.9m	2.3	2.1	48.0
50.0															2.0		50.0

※表中の太線で囲まれた部分は、ブーム等の強度によって定められた値です。

▶ 補助シーブ定格総荷重表 (70tフック装着)

(単位:t)

ブーム長さ 作業半径(m)	15.2	18.3	21.3	24.4	27.4	30.5	33.5	36.6	39.6	42.7	45.7	48.8	51.8	54.9	57.9	61.0	ブーム長さ 作業半径(m)
5.0	12.0/5.3m	12.0/5.8m															5.0
6.0	12.0	12.0	12.0/6.3m	12.0/6.9m													6.0
7.0	12.0	12.0	12.0	12.0	12.0/7.4m	12.0/7.9m											7.0
8.0	12.0	12.0	12.0	12.0	12.0	12.0	12.0/8.4m										8.0
9.0	12.0	12.0	12.0	12.0	12.0	12.0	12.0	12.0/9.0m	12.0/9.5m								9.0
10.0	12.0	12.0	12.0	12.0	12.0	12.0	12.0	12.0	12.0	12.0	12.0/10.6m	12.0/11.1m	12.0/11.6m				10.0
12.0	12.0	12.0	12.0	12.0	12.0	12.0	12.0	12.0	12.0	12.0	12.0	12.0	12.0	12.0/12.2m	12.0/12.7m	12.0/13.2m	12.0
14.0	12.0	12.0	12.0	12.0	12.0	12.0	12.0	12.0	12.0	12.0	12.0	12.0	12.0	12.0	12.0	12.0	14.0
16.0	12.0	12.0	12.0	12.0	12.0	12.0	12.0	12.0	12.0	12.0	12.0	12.0	12.0	12.0	12.0	12.0	16.0
18.0	12.0/16.2m	12.0	12.0	12.0	12.0	12.0	12.0	12.0	12.0	12.0	12.0	12.0	12.0	12.0	12.0	12.0	18.0
20.0		12.0/18.8m	12.0	12.0	12.0	12.0	12.0	12.0	12.0	12.0	12.0	12.0	12.0	12.0	12.0	12.0	20.0
22.0			12.0/21.5m	12.0	12.0	12.0	12.0	12.0	12.0	12.0	12.0	12.0	12.0	12.0	12.0	12.0	22.0
24.0				12.0	12.0	12.0	12.0	12.0	12.0	12.0	12.0	12.0	12.0	12.0	12.0	12.0	24.0
26.0				12.0/24.1m	12.0	12.0	12.0	12.0	12.0	11.8	11.6	11.5	11.4	11.2	11.0	10.9	26.0
28.0					12.0/26.7m	11.1	11.0	10.7	10.6	10.5	10.2	10.2	10.0	9.8	9.6	9.5	28.0
30.0						10.2/29.4m	9.8	9.6	9.5	9.3	9.1	9.0	8.8	8.6	8.5	8.4	30.0
32.0							8.9	8.6	8.5	8.3	8.1	8.0	7.8	7.6	7.5	7.4	32.0
34.0								7.7	7.6	7.4	7.2	7.1	7.0	6.7	6.6	6.5	34.0
36.0								7.4/34.7m	6.9	6.7	6.5	6.4	6.2	6.0	5.8	5.7	36.0
38.0									6.4/37.3m	6.0	5.8	5.7	5.5	5.3	5.1	5.0	38.0
40.0										5.7/39.9m	5.2	5.1	4.9	4.7	4.5	4.4	40.0
42.0											4.7	4.6	4.4	4.2	4.0	3.9	42.0
44.0											4.6/42.6m	4.1	3.9	3.7	3.5	3.4	44.0
46.0												3.8/45.2m	3.5	3.2	3.1	2.9	46.0
48.0													3.1/47.9m	2.8	2.6	2.4	48.0
50.0														2.5	2.2	2.0	50.0
52.0															2.4/50.5m		52.0

※表中の太線で囲まれた部分は、ブーム等の強度によって定められた値です。

▶ 補助シーブ定格総荷重表 (35tフック装着)

(単位:t)

ブーム長さ 作業半径(m)	15.2	18.3	21.3	24.4	27.4	30.5	33.5	36.6	39.6	42.7	45.7	48.8	51.8	54.9	57.9	61.0	ブーム長さ 作業半径(m)
5.0	12.0/5.3m	12.0/5.8m															5.0
6.0	12.0	12.0	12.0/6.3m	12.0/6.9m													6.0
7.0	12.0	12.0	12.0	12.0	12.0/7.4m	12.0/7.9m											7.0
8.0	12.0	12.0	12.0	12.0	12.0	12.0	12.0/8.4m										8.0
9.0	12.0	12.0	12.0	12.0	12.0	12.0	12.0	12.0/9.0m	12.0/9.5m								9.0
10.0	12.0	12.0	12.0	12.0	12.0	12.0	12.0	12.0	12.0	12.0	12.0/10.6m	12.0/11.1m	12.0/11.6m				10.0
12.0	12.0	12.0	12.0	12.0	12.0	12.0	12.0	12.0	12.0	12.0	12.0	12.0	12.0	12.0/12.2m	12.0/12.7m	12.0/13.2m	12.0
14.0	12.0	12.0	12.0	12.0	12.0	12.0	12.0	12.0	12.0	12.0	12.0	12.0	12.0	12.0	12.0	12.0	14.0
16.0	12.0	12.0	12.0	12.0	12.0	12.0	12.0	12.0	12.0	12.0	12.0	12.0	12.0	12.0	12.0	12.0	16.0
18.0	12.0/16.2m	12.0	12.0	12.0	12.0	12.0	12.0	12.0	12.0	12.0	12.0	12.0	12.0	12.0	12.0	12.0	18.0
20.0		12.0/18.8m	12.0	12.0	12.0	12.0	12.0	12.0	12.0	12.0	12.0	12.0	12.0	12.0	12.0	12.0	20.0
22.0			12.0/21.5m	12.0	12.0	12.0	12.0	12.0	12.0	12.0	12.0	12.0	12.0	12.0	12.0	12.0	22.0
24.0				12.0	12.0	12.0	12.0	12.0	12.0	12.0	12.0	12.0	12.0	12.0	12.0	12.0	24.0
26.0				12.0/24.1m	12.0	12.0	12.0	12.0	12.0	12.0	11.9	11.8	11.7	11.5	11.3	11.2	26.0
28.0					12.0/26.7m	11.4	11.3	11.0	10.9	10.8	10.5	10.5	10.3	10.1	9.9	9.8	28.0
30.0						10.5/29.4m	10.1	9.9	9.8	9.6	9.4	9.3	9.1	8.9	8.8	8.7	30.0
32.0							9.2	8.9	8.8	8.6	8.4	8.3	8.1	7.9	7.8	7.7	32.0
34.0								8.0	7.9	7.7	7.5	7.4	7.3	7.0	6.9	6.8	34.0
36.0								7.7/34.7m	7.2	7.0	6.8	6.7	6.5	6.3	6.1	6.0	36.0
38.0									6.7/37.3m	6.3	6.1	6.0	5.8	5.6	5.4	5.3	38.0
40.0										6.0/39.9m	5.5	5.4	5.2	5.0	4.8	4.7	40.0
42.0											5.0	4.9	4.7	4.5	4.3	4.2	42.0
44.0											4.9/42.6m	4.4	4.2	4.0	3.8	3.7	44.0
46.0												4.1/45.2m	3.8	3.5	3.4	3.2	46.0
48.0													3.4/47.9m	3.1	2.9	2.7	48.0
50.0														2.8	2.5	2.3	50.0
52.0															2.7/50.5m	2.1	52.0

※表中の太線で囲まれた部分は、ブーム等の強度によって定められた値です。

▶ 補助シーブ定格総荷重表 (主ブームにフックなし)

(単位:t)

ブーム長さ 作業半径(m)	15.2	18.3	21.3	24.4	27.4	30.5	33.5	36.6	39.6	42.7	45.7	48.8	51.8	54.9	57.9	61.0	ブーム長さ 作業半径(m)
5.0	120/5.3m	120/5.8m															5.0
6.0	12.0	12.0	120/6.3m	120/6.9m													6.0
7.0	12.0	12.0	12.0	12.0	120/7.4m	120/7.9m											7.0
8.0	12.0	12.0	12.0	12.0	12.0	12.0	120/8.4m										8.0
9.0	12.0	12.0	12.0	12.0	12.0	12.0	12.0	120/9.5m									9.0
10.0	12.0	12.0	12.0	12.0	12.0	12.0	12.0	12.0	12.0	12.0	120/10.6m	120/11.1m	120/11.6m				10.0
12.0	12.0	12.0	12.0	12.0	12.0	12.0	12.0	12.0	12.0	12.0	12.0	12.0	12.0	120/12.2m	120/12.7m	120/13.2m	12.0
14.0	12.0	12.0	12.0	12.0	12.0	12.0	12.0	12.0	12.0	12.0	12.0	12.0	12.0	12.0	12.0	12.0	14.0
16.0	12.0	12.0	12.0	12.0	12.0	12.0	12.0	12.0	12.0	12.0	12.0	12.0	12.0	12.0	12.0	12.0	16.0
18.0	120/16.2m	12.0	12.0	12.0	12.0	12.0	12.0	12.0	12.0	12.0	12.0	12.0	12.0	12.0	12.0	12.0	18.0
20.0		120/18.8m	12.0	12.0	12.0	12.0	12.0	12.0	12.0	12.0	12.0	12.0	12.0	12.0	12.0	12.0	20.0
22.0			120/21.5m	12.0	12.0	12.0	12.0	12.0	12.0	12.0	12.0	12.0	12.0	12.0	12.0	12.0	22.0
24.0				12.0	12.0	12.0	12.0	12.0	12.0	12.0	12.0	12.0	12.0	12.0	12.0	12.0	24.0
26.0				120/24.1m	12.0	12.0	12.0	12.0	12.0	12.0	12.0	12.0	12.0	12.0	12.0	12.0	26.0
28.0					120/26.7m	12.0	12.0	11.9	11.8	11.7	11.4	11.4	11.2	11.0	10.8	10.7	28.0
30.0						120/29.4m	11.0	10.8	10.7	10.5	10.3	10.2	10.0	9.8	9.7	9.6	30.0
32.0							10.1	9.8	9.7	9.5	9.3	9.2	9.0	8.8	8.7	8.6	32.0
34.0								8.9	8.8	8.6	8.4	8.3	8.2	7.9	7.8	7.7	34.0
36.0								8.6/34.7m	8.1	7.9	7.7	7.6	7.4	7.2	7.0	6.9	36.0
38.0									7.6/37.3m	7.2	7.0	6.9	6.7	6.5	6.3	6.2	38.0
40.0										6.9/39.9m	6.4	6.3	6.1	5.9	5.7	5.6	40.0
42.0											5.9	5.8	5.6	5.4	5.2	5.1	42.0
44.0											5.8/42.6m	5.3	5.1	4.9	4.7	4.6	44.0
46.0												5.0/45.2m	4.7	4.4	4.3	4.1	46.0
48.0													4.3/47.9m	4.0	3.8	3.6	48.0
50.0														3.7	3.4	3.2	50.0
52.0														3.6/50.5m	3.0	2.8	52.0
54.0															2.7/53.1m	2.4	54.0
56.0																2.0/55.8m	56.0

※表中の太線で囲まれた部分は、ブーム等の強度によって定められた値です。

▶ ロング主ブーム定格総荷重表

(単位:t)

ブーム長さ 作業半径(m)	61.0	64.0	67.1	70.1	73.2	76.2	79.2	ブーム長さ 作業半径(m)
12.0	240/12.3m	240/12.8m	240/13.3m	240/13.9m				12.0
14.0	24.0	24.0	24.0	24.0	22.1/14.4m	18.7/14.9m	16.3/15.4m	14.0
16.0	24.0	24.0	24.0	24.0	20.9	17.9	15.9	16.0
18.0	22.8	22.6	22.5	22.5	19.5	16.7	14.8	18.0
20.0	19.7	19.5	19.5	19.4	18.3	15.7	13.9	20.0
22.0	17.3	17.1	17.0	17.0	16.9	14.8	13.1	22.0
24.0	15.3	15.1	15.0	15.0	14.9	14.0	12.3	24.0
26.0	13.7	13.5	13.4	13.4	13.3	13.1	11.7	26.0
28.0	12.3	12.1	12.0	12.0	11.9	11.7	11.2	28.0
30.0	11.1	10.9	10.8	10.8	10.7	10.6	10.5	30.0
32.0	10.1	9.9	9.8	9.8	9.7	9.5	9.5	32.0
34.0	9.2	9.0	8.9	8.9	8.8	8.7	8.6	34.0
36.0	8.4	8.3	8.2	8.1	8.0	7.9	7.8	36.0
38.0	7.8	7.6	7.5	7.5	7.4	7.2	7.2	38.0
40.0	7.2	7.0	6.9	6.8	6.7	6.6	6.5	40.0
42.0	6.6	6.4	6.3	6.3	6.2	6.0	6.0	42.0
44.0	6.1	5.9	5.8	5.8	5.7	5.5	5.5	44.0
46.0	5.7	5.5	5.4	5.3	5.2	5.1	5.0	46.0
48.0	5.3	5.1	5.0	4.9	4.8	4.7	4.6	48.0
50.0	4.9	4.7	4.6	4.6	4.5	4.3	4.3	50.0
52.0	4.6	4.4	4.3	4.2	4.1	4.0	3.9	52.0
54.0	4.3	4.1	3.9	3.9	3.8	3.6	3.5	54.0
56.0	4.2/54.4m	3.8	3.7	3.6	3.5	3.3	3.2	56.0
58.0		3.6/57.0m	3.4	3.3	3.2	2.9	2.9	58.0
60.0			3.1/59.7m	3.0	2.9	2.6	2.6	60.0
62.0				2.8	2.6	2.4	2.3	62.0
64.0				2.7/62.3m	2.4	2.1	2.0	64.0
66.0					2.2/64.9m			66.0

※表中の太線で囲まれた部分は、ブーム等の強度によって定められた値です。

▶ ロング補助シーブ定格総荷重表 (35tフック装着)

(単位:t)

ブーム長さ 作業半径(m)	61.0	64.0	67.1	70.1	73.2	76.2	ブーム長さ 作業半径(m)
12.0	12.0/12.9m	12.0/13.4m					12.0
14.0	12.0	12.0	12.0	12.0/14.5m	12.0/15.0m	12.0/15.5m	14.0
16.0	12.0	12.0	12.0	12.0	12.0	12.0	16.0
18.0	12.0	12.0	12.0	12.0	12.0	12.0	18.0
20.0	12.0	12.0	12.0	12.0	12.0	12.0	20.0
22.0	12.0	12.0	12.0	12.0	12.0	12.0	22.0
24.0	12.0	12.0	12.0	12.0	12.0	12.0	24.0
26.0	12.0	12.0	12.0	12.0	12.0	11.9	26.0
28.0	11.1	10.9	10.8	10.8	10.7	10.5	28.0
30.0	9.9	9.7	9.6	9.6	9.5	9.4	30.0
32.0	8.9	8.7	8.6	8.6	8.5	8.3	32.0
34.0	8.0	7.8	7.7	7.7	7.6	7.5	34.0
36.0	7.2	7.1	7.0	6.9	6.8	6.7	36.0
38.0	6.6	6.4	6.3	6.3	6.2	6.0	38.0
40.0	6.0	5.8	5.7	5.6	5.5	5.4	40.0
42.0	5.4	5.2	5.1	5.1	5.0	4.8	42.0
44.0	4.9	4.7	4.6	4.6	4.5	4.3	44.0
46.0	4.5	4.3	4.2	4.1	4.0	3.9	46.0
48.0	4.1	3.9	3.8	3.7	3.6	3.5	48.0
50.0	3.7	3.5	3.4	3.4	3.3	3.1	50.0
52.0	3.4	3.2	3.1	3.0	2.9	2.8	52.0
54.0	3.1	2.9	2.7	2.7	2.6	2.4	54.0
56.0	2.9/55.1m	2.6	2.5	2.4	2.3	2.1	56.0
58.0		2.3/57.8m	2.2	2.1	2.0		58.0

※表中の太線で囲まれた部分は、ブーム等の強度によって定められた値です。

▶ ロング補助シーブ定格総荷重表 (主ブームにフックなし)

(単位:t)

ブーム長さ 作業半径(m)	61.0	64.0	67.1	70.1	73.2	76.2	ブーム長さ 作業半径(m)
12.0	12.0/12.9m	12.0/13.4m					12.0
14.0	12.0	12.0	12.0	12.0/14.5m	12.0/15.0m	12.0/15.5m	14.0
16.0	12.0	12.0	12.0	12.0	12.0	12.0	16.0
18.0	12.0	12.0	12.0	12.0	12.0	12.0	18.0
20.0	12.0	12.0	12.0	12.0	12.0	12.0	20.0
22.0	12.0	12.0	12.0	12.0	12.0	12.0	22.0
24.0	12.0	12.0	12.0	12.0	12.0	12.0	24.0
26.0	12.0	12.0	12.0	12.0	12.0	12.0	26.0
28.0	12.0	11.8	11.7	11.7	11.6	11.4	28.0
30.0	10.8	10.6	10.5	10.5	10.4	10.3	30.0
32.0	9.8	9.6	9.5	9.5	9.4	9.2	32.0
34.0	8.9	8.7	8.6	8.6	8.5	8.4	34.0
36.0	8.1	8.0	7.9	7.8	7.7	7.6	36.0
38.0	7.5	7.3	7.2	7.2	7.1	6.9	38.0
40.0	6.9	6.7	6.6	6.5	6.4	6.3	40.0
42.0	6.3	6.1	6.0	6.0	5.9	5.7	42.0
44.0	5.8	5.6	5.5	5.5	5.4	5.2	44.0
46.0	5.4	5.2	5.1	5.0	4.9	4.8	46.0
48.0	5.0	4.8	4.7	4.6	4.5	4.4	48.0
50.0	4.6	4.4	4.3	4.3	4.2	4.0	50.0
52.0	4.3	4.1	4.0	3.9	3.8	3.7	52.0
54.0	4.0	3.8	3.6	3.6	3.5	3.3	54.0
56.0	3.7/55.1m	3.5	3.4	3.3	3.2	3.0	56.0
58.0		3.2/57.8m	3.1	3.0	2.9	2.6	58.0
60.0			2.8	2.7	2.6	2.3	60.0
62.0			2.7/60.4m	2.5	2.3	2.1	62.0
64.0				2.4/63.0m	2.1		64.0
66.0							66.0

※表中の太線で囲まれた部分は、ブーム等の強度によって定められた値です。

▶ジブ定格総荷重表(主フックなし/ジブオフセット角度10°) (単位:t)

ブーム長さ(m) ジブ長さ(m) 作業半径(m)	24.4			27.4			30.5			33.5			ブーム長さ(m) ジブ長さ(m) 作業半径(m)
	18.3	24.4	30.5	18.3	24.4	30.5	18.3	24.4	30.5	18.3	24.4	30.5	
12.0	12.0/12.2m			12.0/12.8m			12.0/13.3m			12.0/13.8m			12.0
14.0	12.0	8.0/14.3m		12.0	8.0/14.9m		12.0	8.0/15.4m		12.0	8.0/15.9m		14.0
16.0	12.0	8.0	4.0/16.4m	12.0	8.0	4.0/16.9m	12.0	8.0	4.0/17.5m	12.0	8.0		16.0
18.0	12.0	8.0	4.0	12.0	8.0	4.0	12.0	8.0	4.0	12.0	8.0	4.0	18.0
20.0	12.0	8.0	4.0	12.0	8.0	4.0	12.0	8.0	4.0	12.0	8.0	4.0	20.0
22.0	12.0	7.6	4.0	12.0	7.8	4.0	12.0	8.0	4.0	12.0	8.0	4.0	22.0
24.0	12.0	7.3	4.0	12.0	7.4	4.0	12.0	7.6	4.0	12.0	7.8	4.0	24.0
26.0	12.0	7.0	4.0	12.0	7.1	4.0	12.0	7.3	4.0	12.0	7.5	4.0	26.0
28.0	11.8	6.7	3.9	12.0	6.9	4.0	12.0	7.0	4.0	12.0	7.2	4.0	28.0
30.0	11.0	6.4	3.7	11.7	6.6	3.8	11.9	6.8	3.9	11.7	6.9	4.0	30.0
32.0	10.3	6.2	3.5	11.0	6.4	3.6	10.9	6.5	3.7	10.7	6.7	3.8	32.0
34.0	9.7	6.0	3.4	10.1	6.2	3.5	10.0	6.3	3.6	9.8	6.5	3.7	34.0
36.0	9.2	5.8	3.2	9.4	6.0	3.3	9.2	6.1	3.4	9.0	6.3	3.5	36.0
38.0	8.7	5.6	3.1	8.7	5.8	3.2	8.5	5.9	3.3	8.3	6.1	3.4	38.0
40.0	8.3	5.5	3.0	8.1	5.6	3.1	7.9	5.8	3.2	7.7	5.9	3.3	40.0
42.0		5.3	2.9	7.5	5.5	3.0	7.3	5.6	3.1	7.2	5.8	3.2	42.0
44.0		5.2	2.8		5.4	2.9	6.9	5.5	3.0	6.7	5.6	3.1	44.0
46.0			2.7		5.2	2.8		5.4	2.9	6.2	5.5	3.0	46.0
48.0			2.6		5.2	2.7		5.3	2.8	5.8	5.4	2.9	48.0
50.0			2.6			2.6		5.2	2.7		5.3	2.8	50.0
52.0						2.6			2.6		5.2	2.7	52.0
54.0									2.6			2.7	54.0
56.0									2.5			2.6	56.0
58.0												2.5	58.0

※表中の太線で囲まれた部分は、ブーム等の強度によって定められた値です。

ブーム長さ(m) ジブ長さ(m) 作業半径(m)	36.6			39.6			42.7			ブーム長さ(m) ジブ長さ(m) 作業半径(m)
	18.3	24.4	30.5	18.3	24.4	30.5	18.3	24.4	30.5	
14.0	12.0/14.4m			12.0/14.9m			12.0/15.4m			14.0
16.0	12.0	8.0/16.4m		12.0	8.0/17.0m		12.0	8.0/17.5m		16.0
18.0	12.0	8.0	4.0/18.5m	12.0	8.0	4.0/19.1m	12.0	8.0	4.0/19.6m	18.0
20.0	12.0	8.0	4.0	12.0	8.0	4.0	12.0	8.0	4.0	20.0
22.0	12.0	8.0	4.0	12.0	8.0	4.0	12.0	8.0	4.0	22.0
24.0	12.0	7.9	4.0	12.0	8.0	4.0	12.0	8.0	4.0	24.0
26.0	12.0	7.6	4.0	12.0	7.8	4.0	12.0	7.9	4.0	26.0
28.0	12.0	7.3	4.0	12.0	7.5	4.0	12.0	7.6	4.0	28.0
30.0	11.5	7.1	4.0	11.4	7.2	4.0	11.2	7.4	4.0	30.0
32.0	10.5	6.9	3.9	10.3	7.0	4.0	10.2	7.1	4.0	32.0
34.0	9.6	6.6	3.8	9.4	6.8	3.9	9.3	6.9	4.0	34.0
36.0	8.8	6.4	3.6	8.7	6.6	3.7	8.5	6.7	3.8	36.0
38.0	8.1	6.2	3.5	8.0	6.4	3.6	7.8	6.5	3.7	38.0
40.0	7.5	6.1	3.4	7.3	6.2	3.5	7.2	6.3	3.6	40.0
42.0	6.9	5.9	3.3	6.8	6.0	3.4	6.6	6.2	3.4	42.0
44.0	6.4	5.8	3.2	6.3	5.9	3.2	6.1	6.0	3.3	44.0
46.0	6.0	5.6	3.1	5.8	5.8	3.1	5.7	5.9	3.2	46.0
48.0	5.6	5.5	3.0	5.4	5.6	3.0	5.2	5.5	3.1	48.0
50.0	5.2	5.4	2.9	5.1	5.3	3.0	4.9	5.1	3.0	50.0
52.0		5.1	2.8	4.7	4.9	2.9	4.5	4.8	3.0	52.0
54.0		4.7	2.7		4.6	2.8	4.2	4.4	2.9	54.0
56.0		4.5	2.7		4.3	2.7	3.9	4.1	2.8	56.0
58.0			2.6		4.0	2.7		3.9	2.7	58.0
60.0			2.5			2.6		3.6	2.7	60.0
62.0						2.6			2.6	62.0
64.0						2.5			2.6	64.0
66.0									2.5	66.0

※表中の太線で囲まれた部分は、ブーム等の強度によって定められた値です。

ブーム長さ(m) ジブ長さ 作業半径(m)	45.7			48.8			51.8			ブーム長さ(m) ジブ長さ 作業半径(m)
	18.3	24.4	30.5	18.3	24.4	30.5	18.3	24.4	30.5	
14.0	12.0/15.9m									14.0
16.0	12.0			12.0/16.5m			12.0/17.0m			16.0
18.0	12.0	8.0		12.0	8.0/18.6m		12.0	8.0/19.1m		18.0
20.0	12.0	8.0	4.0/20.1m	12.0	8.0	4.0/20.6m	12.0	8.0	4.0/21.2m	20.0
22.0	12.0	8.0	4.0	12.0	8.0	4.0	12.0	8.0	4.0	22.0
24.0	12.0	8.0	4.0	12.0	8.0	4.0	12.0	8.0	4.0	24.0
26.0	12.0	8.0	4.0	12.0	8.0	4.0	12.0	8.0	4.0	26.0
28.0	12.0	7.8	4.0	12.0	7.9	4.0	11.9	8.0	4.0	28.0
30.0	11.0	7.5	4.0	10.9	7.6	4.0	10.7	7.8	4.0	30.0
32.0	10.0	7.3	4.0	9.8	7.4	4.0	9.7	7.5	4.0	32.0
34.0	9.1	7.1	4.0	8.9	7.2	4.0	8.8	7.3	4.0	34.0
36.0	8.3	6.8	3.9	8.1	7.0	4.0	8.0	7.1	4.0	36.0
38.0	7.6	6.7	3.8	7.4	6.8	3.8	7.3	6.9	3.9	38.0
40.0	7.0	6.5	3.6	6.8	6.6	3.7	6.6	6.7	3.8	40.0
42.0	6.4	6.3	3.5	6.2	6.4	3.6	6.1	6.4	3.7	42.0
44.0	5.9	6.2	3.4	5.7	6.0	3.5	5.6	5.9	3.6	44.0
46.0	5.4	5.7	3.3	5.3	5.6	3.4	5.1	5.4	3.4	46.0
48.0	5.0	5.3	3.2	4.9	5.1	3.3	4.7	5.0	3.4	48.0
50.0	4.6	4.9	3.1	4.5	4.8	3.2	4.3	4.6	3.3	50.0
52.0	4.3	4.5	3.0	4.1	4.4	3.1	4.0	4.2	3.2	52.0
54.0	4.0	4.2	2.9	3.8	4.1	3.0	3.6	3.9	3.1	54.0
56.0	3.7	3.9	2.9	3.5	3.8	2.9	3.3	3.6	3.0	56.0
58.0	3.4	3.6	2.8	3.2	3.5	2.9	2.9	3.3	2.9	58.0
60.0		3.4	2.7	2.9	3.2	2.8	2.6	3.0	2.9	60.0
62.0		3.1	2.7		2.9	2.7	2.4	2.7	2.8	62.0
64.0			2.9	2.6	2.6	2.7		2.4	2.5	64.0
66.0			2.6		2.4	2.5		2.2	2.3	66.0
68.0			2.5			2.3			2.0	68.0
70.0						2.1				70.0

※表中の太線で囲まれた部分は、ブーム等の強度によって定められた値です。

ブーム長さ(m) ジブ長さ 作業半径(m)	54.9			57.9			61.0			ブーム長さ(m) ジブ長さ 作業半径(m)
	18.3	24.4	30.5	18.3	24.4	30.5	18.3	24.4	30.5	
16.0	12.0/17.5m									16.0
18.0	12.0	8.0/19.6m		12.0/18.1m			12.0/18.6m			18.0
20.0	12.0	8.0	4.0/21.7m	12.0	8.0/20.1m		12.0	8.0/20.7m		20.0
22.0	12.0	8.0	4.0	12.0	8.0	4.0/22.2m	12.0	8.0	4.0/22.8m	22.0
24.0	12.0	8.0	4.0	12.0	8.0	4.0	12.0	8.0	4.0	24.0
26.0	12.0	8.0	4.0	12.0	8.0	4.0	12.0	8.0	4.0	26.0
28.0	11.7	8.0	4.0	11.5	8.0	4.0	11.4	8.0	4.0	28.0
30.0	10.5	7.9	4.0	10.3	8.0	4.0	10.2	8.0	4.0	30.0
32.0	9.5	7.6	4.0	9.3	7.7	4.0	9.1	7.8	4.0	32.0
34.0	8.6	7.4	4.0	8.4	7.5	4.0	8.2	7.6	4.0	34.0
36.0	7.8	7.2	4.0	7.6	7.3	4.0	7.4	7.4	4.0	36.0
38.0	7.1	7.0	4.0	6.9	7.1	4.0	6.7	7.1	4.0	38.0
40.0	6.4	6.8	3.9	6.2	6.6	3.9	6.1	6.4	4.0	40.0
42.0	5.9	6.2	3.7	5.7	6.0	3.8	5.5	5.9	3.9	42.0
44.0	5.4	5.7	3.6	5.2	5.5	3.7	5.0	5.4	3.8	44.0
46.0	4.9	5.2	3.5	4.7	5.0	3.6	4.5	4.9	3.7	46.0
48.0	4.5	4.8	3.4	4.3	4.6	3.5	4.1	4.5	3.6	48.0
50.0	4.1	4.4	3.3	3.9	4.2	3.4	3.6	4.1	3.5	50.0
52.0	3.7	4.0	3.2	3.4	3.9	3.3	3.2	3.6	3.4	52.0
54.0	3.3	3.7	3.2	3.1	3.5	3.2	2.8	3.2	3.3	54.0
56.0	3.0	3.3	3.1	2.7	3.1	3.1	2.5	2.9	3.0	56.0
58.0	2.6	3.0	3.0	2.4	2.8	2.9	2.1	2.5	2.7	58.0
60.0	2.3	2.7	2.8	2.1	2.4	2.6		2.2	2.4	60.0
62.0	2.1	2.4	2.5		2.2	2.3			2.1	62.0
64.0		2.1	2.3			2.0				64.0
66.0			2.0							66.0

※表中の太線で囲まれた部分は、ブーム等の強度によって定められた値です。

▶ジブ定格総荷重表(主フックなし/ジブオフセット角度30°)

(単位:t)

ブーム長さ(m) ジブ長さ(m) 作業半径(m)	24.4				27.4				30.5				33.5				ブーム長さ(m) ジブ長さ(m) 作業半径(m)
	12.2	18.3	24.4	30.5	12.2	18.3	24.4	30.5	12.2	18.3	24.4	30.5	12.2	18.3	24.4	30.5	
12.0	10.0/13.8m																12.0
14.0	10.0				10.0/14.3m				10.0/14.9m				10.0/15.4m				14.0
16.0	10.0	9.0/17.7m			10.0				10.0				10.0				16.0
18.0	10.0	9.0			10.0	9.0/18.3m			10.0	9.0/18.8m			10.0	9.0/19.3m			18.0
20.0	10.0	9.0	6.0/21.7m		10.0	9.0			10.0	9.0			10.0	9.0			20.0
22.0	10.0	9.0	6.0		10.0	9.0	6.0/22.2m		10.0	9.0	6.0/22.7m		10.0	9.0	6.0/23.2m		22.0
24.0	10.0	9.0	6.0	3.0/25.6m	10.0	9.0	6.0		10.0	9.0	6.0		10.0	9.0	6.0		24.0
26.0	10.0	9.0	6.0	3.0	10.0	9.0	6.0	3.0/26.1m	10.0	9.0	6.0	3.0/26.6m	10.0	9.0	6.0	3.0/27.2m	26.0
28.0	10.0	8.7	5.8	3.0	10.0	9.0	5.9	3.0	10.0	9.0	6.0	3.0	10.0	9.0	6.0	3.0	28.0
30.0	10.0	8.3	5.7	3.0	10.0	8.6	5.8	3.0	10.0	8.9	5.8	3.0	10.0	9.0	5.9	3.0	30.0
32.0	10.0	7.9	5.5	3.0	10.0	8.2	5.6	3.0	10.0	8.5	5.7	3.0	10.0	8.7	5.8	3.0	32.0
34.0	10.0	7.6	5.4	2.9	10.0	7.9	5.5	3.0	9.9	8.1	5.6	3.0	9.8	8.4	5.6	3.0	34.0
36.0		7.3	5.3	2.8	9.3	7.6	5.4	2.9	9.1	7.8	5.5	2.9	9.0	8.1	5.5	3.0	36.0
38.0		7.1	5.2	2.7		7.3	5.3	2.8	8.4	7.5	5.4	2.8	8.3	7.8	5.4	2.9	38.0
40.0		6.9	5.1	2.7		7.1	5.2	2.7	7.8	7.3	5.3	2.8	7.6	7.5	5.3	2.8	40.0
42.0			5.0	2.6		6.9	5.1	2.7		7.1	5.2	2.7	7.1	7.3	5.2	2.7	42.0
44.0			4.8	2.6			5.0	2.6		7.0	5.1	2.6		6.9	5.2	2.7	44.0
46.0			4.7	2.5			4.8	2.5		6.5	5.0	2.6		6.4	5.1	2.6	46.0
48.0				2.5			4.7	2.5			4.8	2.5		6.0	5.0	2.6	48.0
50.0				2.4				2.5			4.8	2.5			4.9	2.5	50.0
52.0				2.4				2.4			4.7	2.5			4.8	2.5	52.0
54.0								2.4				2.4			4.7	2.5	54.0
56.0												2.4				2.4	56.0
58.0												2.4				2.4	58.0
60.0																2.4	60.0

※表中の太線で囲まれた部分は、ブーム等の強度によって定められた値です。

ブーム長さ(m) ジブ長さ(m) 作業半径(m)	36.6				39.6				42.7				ブーム長さ(m) ジブ長さ(m) 作業半径(m)
	12.2	18.3	24.4	30.5	12.2	18.3	24.4	30.5	12.2	18.3	24.4	30.5	
14.0	10.0/15.9m												14.0
16.0	10.0				10.0/16.5m				10.0/17.0m				16.0
18.0	10.0	9.0/19.9m			10.0				10.0				18.0
20.0	10.0	9.0			10.0	9.0/20.4m			10.0	9.0/20.9m			20.0
22.0	10.0	9.0	6.0/23.8m		10.0	9.0			10.0	9.0			22.0
24.0	10.0	9.0	6.0		10.0	9.0	6.0/24.3m		10.0	9.0	6.0/24.8m		24.0
26.0	10.0	9.0	6.0	3.0/27.7m	10.0	9.0	6.0		10.0	9.0	6.0		26.0
28.0	10.0	9.0	6.0	3.0	10.0	9.0	6.0	3.0/28.2m	10.0	9.0	6.0	3.0/28.8m	28.0
30.0	10.0	9.0	6.0	3.0	10.0	9.0	6.0	3.0	10.0	9.0	6.0	3.0	30.0
32.0	10.0	9.0	5.8	3.0	10.0	9.0	5.9	3.0	10.0	9.0	5.9	3.0	32.0
34.0	9.6	8.6	5.7	3.0	9.5	8.9	5.8	3.0	9.3	9.0	5.8	3.0	34.0
36.0	8.8	8.3	5.6	3.0	8.7	8.5	5.6	3.0	8.5	8.7	5.7	3.0	36.0
38.0	8.1	8.0	5.5	2.9	7.9	8.2	5.5	3.0	7.8	8.3	5.6	3.0	38.0
40.0	7.4	7.8	5.4	2.8	7.3	7.7	5.4	2.9	7.1	7.6	5.5	2.9	40.0
42.0	6.9	7.3	5.3	2.8	6.7	7.1	5.4	2.8	6.6	7.0	5.4	2.8	42.0
44.0	6.3	6.7	5.2	2.7	6.2	6.6	5.3	2.7	6.1	6.5	5.3	2.8	44.0
46.0		6.2	5.2	2.7	5.7	6.1	5.2	2.7	5.6	6.0	5.3	2.7	46.0
48.0		5.8	5.1	2.6	5.3	5.7	5.2	2.6	5.1	5.5	5.2	2.7	48.0
50.0		5.4	5.0	2.6		5.3	5.1	2.6	4.8	5.1	5.1	2.6	50.0
52.0		5.0	4.9	2.5		4.9	5.0	2.5		4.7	5.0	2.6	52.0
54.0			4.8	2.5		4.5	4.8	2.5		4.4	4.6	2.5	54.0
56.0			4.6	2.5			4.5	2.5		4.1	4.3	2.5	56.0
58.0				2.4			4.1	2.5			4.0	2.5	58.0
60.0				2.4			3.9	2.4			3.7	2.4	60.0
62.0				2.4				2.4			3.5	2.4	62.0
64.0												2.4	64.0
66.0								2.4				2.4	66.0

※表中の太線で囲まれた部分は、ブーム等の強度によって定められた値です。

ブーム長さ(m) ジブ長さ (m) 作業半径(m)	45.7				48.8				51.8				ブーム長さ(m) ジブ長さ (m) 作業半径(m)
	12.2	18.3	24.4	30.5	12.2	18.3	24.4	30.5	12.2	18.3	24.4	30.5	
16.0	10.0/17.5m												16.0
18.0	10.0				10.0/18.1m				10.0/18.6m				18.0
20.0	10.0	9.0/21.4m			10.0				10.0				20.0
22.0	10.0	9.0			10.0	9.0			10.0	9.0/22.5m			22.0
24.0	10.0	9.0	6.0/25.4m		10.0	9.0	6.0/25.9m		10.0	9.0			24.0
26.0	10.0	9.0	6.0		10.0	9.0	6.0		10.0	9.0	6.0/26.4m		26.0
28.0	10.0	9.0	6.0	3.0/29.3m	10.0	9.0	6.0	3.0/29.8m	10.0	9.0	6.0		28.0
30.0	10.0	9.0	6.0	3.0	10.0	9.0	6.0	3.0	10.0	9.0	6.0	3.0/30.3m	30.0
32.0	10.0	9.0	6.0	3.0	10.0	9.0	6.0	3.0	9.8	9.0	6.0	3.0	32.0
34.0	9.1	9.0	5.9	3.0	9.0	9.0	5.9	3.0	8.9	9.0	6.0	3.0	34.0
36.0	8.3	8.8	5.8	3.0	8.2	8.7	5.8	3.0	8.1	8.6	5.9	3.0	36.0
38.0	7.6	8.1	5.7	3.0	7.5	8.0	5.7	3.0	7.3	7.9	5.8	3.0	38.0
40.0	7.0	7.4	5.6	2.9	6.8	7.3	5.6	3.0	6.7	7.2	5.7	3.0	40.0
42.0	6.4	6.8	5.5	2.9	6.2	6.7	5.5	2.9	6.1	6.6	5.6	2.9	42.0
44.0	5.8	6.3	5.4	2.8	5.7	6.2	5.4	2.8	5.6	6.0	5.5	2.9	44.0
46.0	5.4	5.8	5.3	2.8	5.2	5.7	5.4	2.8	5.1	5.5	5.4	2.8	46.0
48.0	4.9	5.3	5.2	2.7	4.8	5.2	5.3	2.7	4.7	5.1	5.3	2.8	48.0
50.0	4.6	4.9	5.2	2.7	4.4	4.8	5.1	2.7	4.3	4.7	5.0	2.7	50.0
52.0	4.2	4.6	4.8	2.6	4.1	4.4	4.7	2.6	3.9	4.3	4.6	2.7	52.0
54.0		4.2	4.5	2.6	3.7	4.1	4.4	2.6	3.5	4.0	4.2	2.6	54.0
56.0		3.9	4.1	2.5	3.4	3.8	4.0	2.6	3.1	3.6	3.9	2.6	56.0
58.0		3.6	3.8	2.5		3.5	3.7	2.5	2.8	3.3	3.6	2.5	58.0
60.0		3.3	3.6	2.5		3.1	3.4	2.5		2.9	3.3	2.5	60.0
62.0			3.3	2.4		2.8	3.2	2.5		2.6	3.0	2.5	62.0
64.0			3.0	2.4			2.8	2.4		2.3	2.7	2.5	64.0
66.0				2.4			2.6	2.4			2.4	2.4	66.0
68.0				2.4			2.3	2.4			2.1	2.4	68.0
70.0				2.4				2.3				2.1	70.0
72.0								2.1					72.0

※表中の太線で囲まれた部分は、ブーム等の強度によって定められた値です。

ブーム長さ(m) ジブ長さ (m) 作業半径(m)	54.9				57.9				61.0				ブーム長さ(m) ジブ長さ (m) 作業半径(m)
	12.2	18.3	24.4	30.5	12.2	18.3	24.4	30.5	12.2	18.3	24.4	30.5	
18.0	10.0/19.1m				10.0/19.6m								18.0
20.0	10.0				10.0				10.0/20.1m				20.0
22.0	10.0	9.0/23.0m			10.0	9.0/23.6m			10.0				22.0
24.0	10.0	9.0			10.0	9.0			10.0	9.0/24.1m			24.0
26.0	10.0	9.0	6.0/26.9m		10.0	9.0	6.0/27.5m		10.0	9.0			26.0
28.0	10.0	9.0	6.0		10.0	9.0	6.0		10.0	9.0	6.0		28.0
30.0	10.0	9.0	6.0	3.0/30.9m	10.0	9.0	6.0	3.0/31.4m	10.0	9.0	6.0	3.0/31.9m	30.0
32.0	9.6	9.0	6.0	3.0	9.5	9.0	6.0	3.0	9.3	9.0	6.0	3.0	32.0
34.0	8.7	9.0	6.0	3.0	8.5	9.0	6.0	3.0	8.4	9.0	6.0	3.0	34.0
36.0	7.9	8.5	5.9	3.0	7.7	8.3	5.9	3.0	7.6	8.2	6.0	3.0	36.0
38.0	7.1	7.7	5.8	3.0	7.0	7.6	5.8	3.0	6.8	7.4	5.9	3.0	38.0
40.0	6.5	7.0	5.7	3.0	6.3	6.9	5.7	3.0	6.2	6.8	5.8	3.0	40.0
42.0	5.9	6.4	5.6	3.0	5.7	6.3	5.7	3.0	5.6	6.1	5.7	3.0	42.0
44.0	5.4	5.9	5.5	2.9	5.2	5.7	5.6	2.9	5.1	5.6	5.6	3.0	44.0
46.0	4.9	5.4	5.5	2.8	4.7	5.2	5.5	2.9	4.6	5.1	5.5	2.9	46.0
48.0	4.5	4.9	5.2	2.8	4.3	4.8	5.1	2.8	4.1	4.6	5.0	2.8	48.0
50.0	4.1	4.5	4.8	2.7	3.8	4.4	4.7	2.8	3.6	4.2	4.6	2.8	50.0
52.0	3.6	4.1	4.4	2.7	3.4	4.0	4.3	2.7	3.2	3.8	4.2	2.7	52.0
54.0	3.2	3.8	4.1	2.6	3.0	3.6	3.9	2.7	2.8	3.4	3.8	2.7	54.0
56.0	2.8	3.4	3.7	2.6	2.6	3.2	3.6	2.6	2.4	3.0	3.4	2.7	56.0
58.0	2.5	3.0	3.4	2.6	2.3	2.8	3.2	2.6	2.0	2.6	3.0	2.6	58.0
60.0	2.2	2.7	3.1	2.5	2.0	2.5	2.9	2.6		2.3	2.7	2.6	60.0
62.0		2.4	2.7	2.5		2.2	2.5	2.5		2.0	2.3	2.5	62.0
64.0		2.1	2.4	2.5			2.2	2.5			2.0	2.3	64.0
66.0			2.1	2.4				2.2				2.0	66.0
68.0				2.1									68.0

※表中の太線で囲まれた部分は、ブーム等の強度によって定められた値です。



主ブーム定格総荷重表 (45.1tカウンタウエイト)(オプション)

(単位:t)

ジブの長さ 作業半径(m)	15.2	18.3	21.3	24.4	27.4	30.5	33.5	36.6	39.6	42.7	45.7	48.8	51.8	54.9	57.9	61.0	ジブの長さ 作業半径(m)
4.5	120.0																4.5
5.0	120.0	108.0/5.1m	96.0/5.6m														5.0
6.0	100.0	99.8	94.9	84.0/6.1m	74.6/6.7m												6.0
7.0	78.8	78.7	78.6	78.6	73.7	66.4/7.2m	59.4/7.7m										7.0
8.0	63.2	63.1	63.0	63.0	62.8	62.8	58.9	53.6/8.2m	48.0/8.8m								8.0
9.0	52.7	52.5	52.4	52.4	52.2	52.2	52.1	52.0	48.0	43.5/9.3m	39.6/9.8m						9.0
10.0	45.0	44.9	44.8	44.7	44.5	44.5	44.4	44.3	44.2	42.8	39.5	36.0/10.4m	32.1/10.9m	29.4/11.4m			10.0
12.0	34.8	34.6	34.4	34.4	34.2	34.1	34.1	33.9	33.8	33.7	33.5	33.5	31.4	29.0	26.9	24.0/12.5m	12.0
14.0	28.2	28.0	27.8	27.7	27.5	27.5	27.4	27.2	27.1	27.0	26.8	26.8	26.7	26.5	25.9	23.5	14.0
16.0	25.9/14.9m	23.4	23.2	23.1	22.9	22.8	22.7	22.5	22.5	22.3	22.2	22.1	22.0	21.8	21.6	21.6	16.0
18.0		20.8/17.5m	19.8	19.7	19.5	19.4	19.3	19.1	19.0	18.9	18.7	18.7	18.5	18.3	18.2	18.1	18.0
20.0			17.2	17.1	16.9	16.8	16.7	16.5	16.4	16.3	16.1	16.0	15.9	15.7	15.5	15.5	20.0
22.0			17.2/20.1m	15.1	14.8	14.7	14.6	14.4	14.3	14.2	14.0	13.9	13.8	13.6	13.4	13.4	22.0
24.0				14.4/22.8m	13.2	13.1	12.9	12.7	12.6	12.5	12.3	12.2	12.1	11.9	11.7	11.6	24.0
26.0					12.2/25.4m	11.7	11.6	11.3	11.3	11.1	10.9	10.8	10.7	10.5	10.3	10.2	26.0
28.0						10.5	10.4	10.2	10.1	9.9	9.7	9.7	9.5	9.3	9.1	9.1	28.0
30.0							9.4	9.2	9.1	8.9	8.7	8.6	8.5	8.3	8.1	8.0	30.0
32.0							9.1/30.7m	8.4	8.2	8.1	7.9	7.8	7.6	7.4	7.3	7.2	32.0
34.0								7.9/33.3m	7.5	7.3	7.1	7.0	6.9	6.7	6.5	6.4	34.0
36.0									6.9	6.7	6.5	6.4	6.2	6.0	5.8	5.7	36.0
38.0										6.1	5.9	5.8	5.6	5.4	5.3	5.1	38.0
40.0										6.0/38.6m	5.4	5.3	5.1	4.9	4.7	4.6	40.0
42.0											5.1/41.2m	4.8	4.6	4.4	4.2	4.1	42.0
44.0												4.4/43.9m	4.2	4.0	3.8	3.7	44.0
46.0													3.8	3.6	3.4	3.3	46.0
48.0													3.8/46.5m	3.3	3.1	2.9	48.0
50.0														3.1/49.2m	2.6	2.5	50.0
52.0															2.3/51.8m	2.1	52.0

※表中の太線で囲まれた部分は、ブーム等の強度によって定められた値です。



補助シーブ定格総荷重表 (45.1tカウンタウエイト、120tフック装着)(オプション)

(単位:t)

ジブの長さ 作業半径(m)	15.2	18.3	21.3	24.4	27.4	30.5	33.5	36.6	39.6	42.7	45.7	48.8	51.8	54.9	57.9	61.0	ジブの長さ 作業半径(m)
5.0	12.0/5.3m	12.0/5.8m															5.0
6.0	12.0	12.0	12.0/6.3m	12.0/6.9m													6.0
7.0	12.0	12.0	12.0	12.0	12.0/7.4m	12.0/7.9m											7.0
8.0	12.0	12.0	12.0	12.0	12.0	12.0	12.0	12.0/8.4m									8.0
9.0	12.0	12.0	12.0	12.0	12.0	12.0	12.0	12.0	12.0/9.5m								9.0
10.0	12.0	12.0	12.0	12.0	12.0	12.0	12.0	12.0	12.0	12.0	12.0/10.6m	12.0/11.1m	12.0/11.6m				10.0
12.0	12.0	12.0	12.0	12.0	12.0	12.0	12.0	12.0	12.0	12.0	12.0	12.0	12.0	12.0/12.2m	12.0/12.7m	12.0/13.2m	12.0
14.0	12.0	12.0	12.0	12.0	12.0	12.0	12.0	12.0	12.0	12.0	12.0	12.0	12.0	12.0	12.0	12.0	14.0
16.0	12.0	12.0	12.0	12.0	12.0	12.0	12.0	12.0	12.0	12.0	12.0	12.0	12.0	12.0	12.0	12.0	16.0
18.0	12.0/16.2m	12.0	12.0	12.0	12.0	12.0	12.0	12.0	12.0	12.0	12.0	12.0	12.0	12.0	12.0	12.0	18.0
20.0		12.0/18.8m	12.0	12.0	12.0	12.0	12.0	12.0	12.0	12.0	12.0	12.0	12.0	12.0	12.0	12.0	20.0
22.0			12.0/21.5m	12.0	12.0	12.0	12.0	12.0	12.0	12.0	12.0	11.9	11.8	11.6	11.4	11.4	22.0
24.0				11.3	11.2	11.1	10.9	10.7	10.6	10.5	10.3	10.2	10.1	9.9	9.7	9.6	24.0
26.0				11.2/24.1m	9.7	9.7	9.6	9.3	9.3	9.1	8.9	8.8	8.7	8.5	8.3	8.2	26.0
28.0					9.2/26.7m	8.5	8.4	8.2	8.1	7.9	7.7	7.7	7.5	7.3	7.1	7.1	28.0
30.0						7.6/29.4m	7.4	7.2	7.1	6.9	6.7	6.6	6.5	6.3	6.1	6.0	30.0
32.0							6.5	6.4	6.2	6.1	5.9	5.8	5.6	5.4	5.3	5.2	32.0
34.0								5.6	5.5	5.3	5.1	5.0	4.9	4.7	4.5	4.4	34.0
36.0								5.3/34.7m	4.9	4.7	4.5	4.4	4.2	4.0	3.8	3.7	36.0
38.0									4.5/37.3m	4.1	3.9	3.8	3.6	3.4	3.3	3.1	38.0
40.0										3.7/39.9m	3.4	3.3	3.1	2.9	2.7	2.6	40.0
42.0											2.9	2.8	2.6	2.4	2.2	2.1	42.0
44.0											2.7/42.6m	2.3	2.2	2.0			44.0
46.0												2.1/45.2m					46.0

※表中の太線で囲まれた部分は、ブーム等の強度によって定められた値です。



▶ 補助シーブ定格総荷重表 (45.1tカウンタウエイト、70tフック装着)(オプション)

(単位:t)

ジブの長さ 作業半径(m)	15.2	18.3	21.3	24.4	27.4	30.5	33.5	36.6	39.6	42.7	45.7	48.8	51.8	54.9	57.9	61.0	ジブの長さ 作業半径(m)
5.0	12.0/5.3m	12.0/5.8m															5.0
6.0	12.0	12.0	12.0/6.3m	12.0/6.9m													6.0
7.0	12.0	12.0	12.0	12.0	12.0/7.4m	12.0/7.9m											7.0
8.0	12.0	12.0	12.0	12.0	12.0	12.0	12.0/8.4m										8.0
9.0	12.0	12.0	12.0	12.0	12.0	12.0	12.0	12.0	12.0/9.5m								9.0
10.0	12.0	12.0	12.0	12.0	12.0	12.0	12.0	12.0	12.0	12.0	12.0/10.6m	12.0/11.1m	12.0/11.6m				10.0
12.0	12.0	12.0	12.0	12.0	12.0	12.0	12.0	12.0	12.0	12.0	12.0	12.0	12.0	12.0/12.2m	12.0/12.7m	12.0/13.2m	12.0
14.0	12.0	12.0	12.0	12.0	12.0	12.0	12.0	12.0	12.0	12.0	12.0	12.0	12.0	12.0	12.0	12.0	14.0
16.0	12.0	12.0	12.0	12.0	12.0	12.0	12.0	12.0	12.0	12.0	12.0	12.0	12.0	12.0	12.0	12.0	16.0
18.0	12.0/16.2m	12.0	12.0	12.0	12.0	12.0	12.0	12.0	12.0	12.0	12.0	12.0	12.0	12.0	12.0	12.0	18.0
20.0		12.0/18.8m	12.0	12.0	12.0	12.0	12.0	12.0	12.0	12.0	12.0	12.0	12.0	12.0	12.0	12.0	20.0
22.0			12.0/21.5m	12.0	12.0	12.0	12.0	12.0	12.0	12.0	12.0	12.0	12.0	12.0	11.9	11.9	22.0
24.0				11.8	11.7	11.6	11.4	11.2	11.1	11.0	10.8	10.7	10.6	10.4	10.2	10.1	24.0
26.0				11.7/24.1m	10.2	10.2	10.1	9.8	9.8	9.6	9.4	9.3	9.2	9.0	8.8	8.7	26.0
28.0					9.7/26.7m	9.0	8.9	8.7	8.6	8.4	8.2	8.2	8.0	7.8	7.6	7.6	28.0
30.0						8.1/29.4m	7.9	7.7	7.6	7.4	7.2	7.1	7.0	6.8	6.6	6.5	30.0
32.0							7.0	6.9	6.7	6.6	6.4	6.3	6.1	5.9	5.8	5.7	32.0
34.0								6.1	6.0	5.8	5.6	5.5	5.4	5.2	5.0	4.9	34.0
36.0								5.8/34.7m	5.4	5.2	5.0	4.9	4.7	4.5	4.3	4.2	36.0
38.0									5.0/37.3m	4.6	4.4	4.3	4.1	3.9	3.8	3.6	38.0
40.0										4.2/39.9m	3.9	3.8	3.6	3.4	3.2	3.1	40.0
42.0											3.4	3.3	3.1	2.9	2.7	2.6	42.0
44.0											3.2/42.6m	2.8	2.7	2.5	2.3	2.2	44.0
46.0												2.6/45.2m	2.3	2.1			46.0
48.0													2.0/47.9m				48.0

※表中の太線で囲まれた部分は、ブーム等の強度によって定められた値です。



▶ 補助シーブ定格総荷重表 (45.1tカウンタウエイト、35tフック装着)(オプション)

(単位:t)

ジブの長さ 作業半径(m)	15.2	18.3	21.3	24.4	27.4	30.5	33.5	36.6	39.6	42.7	45.7	48.8	51.8	54.9	57.9	61.0	ジブの長さ 作業半径(m)
5.0	12.0/5.3m	12.0/5.8m															5.0
6.0	12.0	12.0	12.0/6.3m	12.0/6.9m													6.0
7.0	12.0	12.0	12.0	12.0	12.0/7.4m	12.0/7.9m											7.0
8.0	12.0	12.0	12.0	12.0	12.0	12.0	12.0/8.4m										8.0
9.0	12.0	12.0	12.0	12.0	12.0	12.0	12.0	12.0	12.0/9.5m								9.0
10.0	12.0	12.0	12.0	12.0	12.0	12.0	12.0	12.0	12.0	12.0	12.0/10.6m	12.0/11.1m	12.0/11.6m				10.0
12.0	12.0	12.0	12.0	12.0	12.0	12.0	12.0	12.0	12.0	12.0	12.0	12.0	12.0	12.0/12.2m	12.0/12.7m	12.0/13.2m	12.0
14.0	12.0	12.0	12.0	12.0	12.0	12.0	12.0	12.0	12.0	12.0	12.0	12.0	12.0	12.0	12.0	12.0	14.0
16.0	12.0	12.0	12.0	12.0	12.0	12.0	12.0	12.0	12.0	12.0	12.0	12.0	12.0	12.0	12.0	12.0	16.0
18.0	12.0/16.2m	12.0	12.0	12.0	12.0	12.0	12.0	12.0	12.0	12.0	12.0	12.0	12.0	12.0	12.0	12.0	18.0
20.0		12.0/18.8m	12.0	12.0	12.0	12.0	12.0	12.0	12.0	12.0	12.0	12.0	12.0	12.0	12.0	12.0	20.0
22.0			12.0/21.5m	12.0	12.0	12.0	12.0	12.0	12.0	12.0	12.0	12.0	12.0	12.0	12.0	12.0	22.0
24.0				12.0	12.0	11.9	11.7	11.5	11.4	11.3	11.1	11.0	10.9	10.7	10.5	10.4	24.0
26.0				12.0/24.1m	10.5	10.5	10.4	10.1	10.1	9.9	9.7	9.6	9.5	9.3	9.1	9.0	26.0
28.0					10.0/26.7m	9.3	9.2	9.0	8.9	8.7	8.5	8.5	8.3	8.1	7.9	7.9	28.0
30.0						8.4/29.4m	8.2	8.0	7.9	7.7	7.5	7.4	7.3	7.1	6.9	6.8	30.0
32.0							7.3	7.2	7.0	6.9	6.7	6.6	6.4	6.2	6.1	6.0	32.0
34.0								6.4	6.3	6.1	5.9	5.8	5.7	5.5	5.3	5.2	34.0
36.0								6.1/34.7m	5.7	5.5	5.3	5.2	5.0	4.8	4.6	4.5	36.0
38.0									5.3/37.3m	4.9	4.7	4.6	4.4	4.2	4.1	3.9	38.0
40.0										4.5/39.9m	4.2	4.1	3.9	3.7	3.5	3.4	40.0
42.0											3.7	3.6	3.4	3.2	3.0	2.9	42.0
44.0											3.5/42.6m	3.1	3.0	2.8	2.6	2.5	44.0
46.0												2.9/45.2m	2.6	2.4	2.2	2.1	46.0
48.0													2.3/47.9m	2.1			48.0

※表中の太線で囲まれた部分は、ブーム等の強度によって定められた値です。



▶ 補助シーブ定格総荷重表 (45.1tカウンタウイト、主フックなし)(オプション)

(単位:t)

ジブの長さ 作業半径(m)	15.2	18.3	21.3	24.4	27.4	30.5	33.5	36.6	39.6	42.7	45.7	48.8	51.8	54.9	57.9	61.0	ジブの長さ 作業半径(m)
5.0	12.0/5.3m	12.0/5.8m															5.0
6.0	12.0	12.0	12.0/6.3m	12.0/6.9m													6.0
7.0	12.0	12.0	12.0	12.0	12.0/7.4m	12.0/7.9m											7.0
8.0	12.0	12.0	12.0	12.0	12.0	12.0	12.0/8.4m										8.0
9.0	12.0	12.0	12.0	12.0	12.0	12.0	12.0	12.0	12.0/9.5m								9.0
10.0	12.0	12.0	12.0	12.0	12.0	12.0	12.0	12.0	12.0	12.0	12.0/10.6m	12.0/11.1m	12.0/11.6m				10.0
12.0	12.0	12.0	12.0	12.0	12.0	12.0	12.0	12.0	12.0	12.0	12.0	12.0	12.0	12.0/12.2m	12.0/12.7m	12.0/13.2m	12.0
14.0	12.0	12.0	12.0	12.0	12.0	12.0	12.0	12.0	12.0	12.0	12.0	12.0	12.0	12.0	12.0	12.0	14.0
16.0	12.0	12.0	12.0	12.0	12.0	12.0	12.0	12.0	12.0	12.0	12.0	12.0	12.0	12.0	12.0	12.0	16.0
18.0	12.0/16.2m	12.0	12.0	12.0	12.0	12.0	12.0	12.0	12.0	12.0	12.0	12.0	12.0	12.0	12.0	12.0	18.0
20.0		12.0/18.8m	12.0	12.0	12.0	12.0	12.0	12.0	12.0	12.0	12.0	12.0	12.0	12.0	12.0	12.0	20.0
22.0			12.0/21.5m	12.0	12.0	12.0	12.0	12.0	12.0	12.0	12.0	12.0	12.0	12.0	12.0	12.0	22.0
24.0				12.0	12.0	12.0	12.0	12.0	12.0	12.0	12.0	11.9	11.8	11.6	11.4	11.3	24.0
26.0				12.0/24.1m	11.4	11.4	11.3	11.0	11.0	10.8	10.6	10.5	10.4	10.2	10.0	9.9	26.0
28.0					10.9/26.7m	10.2	10.1	9.9	9.8	9.6	9.4	9.4	9.2	9.0	8.8	8.8	28.0
30.0						9.3/29.4m	9.1	8.9	8.8	8.6	8.4	8.3	8.2	8.0	7.8	7.7	30.0
32.0							8.2	8.1	7.9	7.8	7.6	7.5	7.3	7.1	7.0	6.9	32.0
34.0								7.3	7.2	7.0	6.8	6.7	6.6	6.4	6.2	6.1	34.0
36.0								7.0/34.7m	6.6	6.4	6.2	6.1	5.9	5.7	5.5	5.4	36.0
38.0									6.2/37.3m	5.8	5.6	5.5	5.3	5.1	5.0	4.8	38.0
40.0										5.4/39.9m	5.1	5.0	4.8	4.6	4.4	4.3	40.0
42.0											4.6	4.5	4.3	4.1	3.9	3.8	42.0
44.0											4.4/42.6m	4.0	3.9	3.7	3.5	3.4	44.0
46.0												3.8/45.2m	3.5	3.3	3.1	3.0	46.0
48.0													3.2/47.9m	3.0	2.8	2.6	48.0
50.0														2.6	2.3	2.2	50.0
52.0														2.5/50.5m			52.0

※表中の太線で囲まれた部分は、ブーム等の強度によって定められた値です。

ラッピングタワー

全体図(単位: mm)

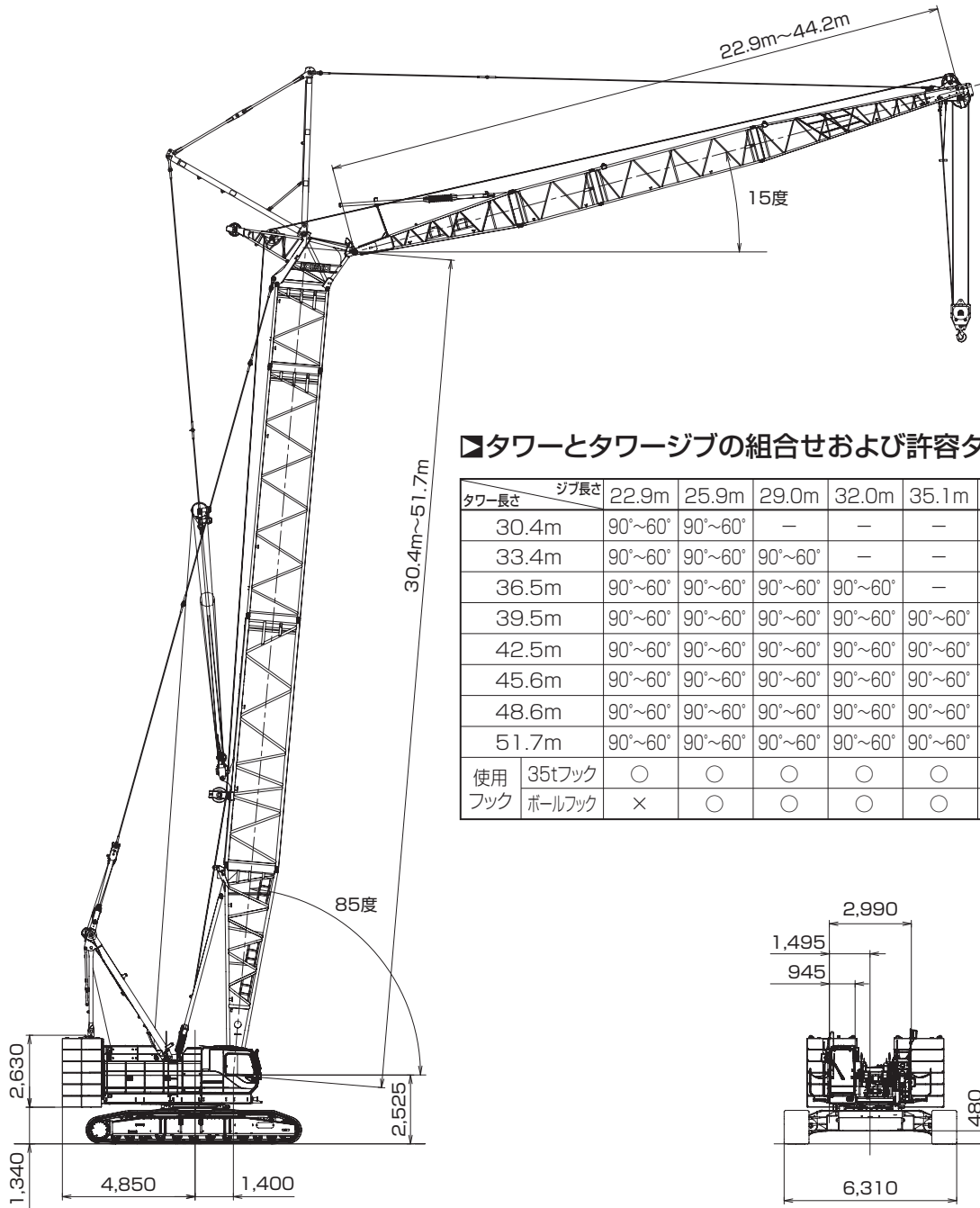

タワーとタワージブの組合せおよび許容タワー傾斜角度

タワー長さ	ジブ長さ	22.9m	25.9m	29.0m	32.0m	35.1m	38.1m	41.1m	44.2m	敷板
30.4m		90°~60°	90°~60°	—	—	—	—	—	—	—
33.4m		90°~60°	90°~60°	90°~60°	—	—	—	—	—	—
36.5m		90°~60°	90°~60°	90°~60°	90°~60°	—	—	—	—	—
39.5m		90°~60°	90°~60°	90°~60°	90°~60°	90°~60°	—	—	—	—
42.5m		90°~60°	90°~60°	90°~60°	90°~60°	90°~60°	90°~60°	—	—	—
45.6m		90°~60°	90°~60°	90°~60°	90°~60°	90°~60°	90°~60°	90°~60°	—	—
48.6m		90°~60°	90°~60°	90°~60°	90°~60°	90°~60°	90°~60°	90°~60°	90°~70°	—
51.7m		90°~60°	90°~60°	90°~60°	90°~60°	90°~60°	90°~70°	90°~70°	90°~70°	◎
使用 フック	35tフック	○	○	○	○	○	○	○	○	⊗
	ボールフック	×	○	○	○	○	○	○	○	

○: 使用可 ×: 使用不可 ◎: 必要

■タワー構成

- ※印は、これより短いタワーの組立可能な構成を示します。
- 9.1Aは、クローラークレーンの中間ブームとしても使用できます。
- 下部ブーム直近の9.1m中間ブームには、9.1Aを使用してください。
- 使用するガイラインの径はφ30mmです。

中間タワーの種類		
記号	タワー長さ	備考
3.0	3.0m	クレーンおよびタワー共用
6.1	6.1m	クレーンおよびタワー共用
9.1	9.1m	クレーンおよびタワー共用
9.1A	9.1m	タワー専用 (クレーンに兼用可能)

■タワージブ構成

- ※印は、これより短いタワージブの組立可能な構成を示します。
- 印は、ケーブルローラ取付位置を示します。
- 使用するガイラインの径はφ30mmです。

中間タワージブの種類		
記号	タワージブ長さ	備考
3.0A	3.0m	中継ジブ
3.0	3.0m	
6.1	6.1m	
9.1	9.1m	

タワー長さ m (ft.)	タワー構成
30.4 (100)	
33.4 (110)	※
36.5 (120)	※
39.5 (130)	※
42.5 (140)	※
45.6 (150)	※
48.6 (160)	※
51.7 (170)	※

タワー長さ m (ft.)	タワージブ構成
22.9 (75)	※
25.9 (85)	※
29.0 (95)	※
32.0 (105)	※
35.1 (115)	※
38.1 (125)	※
41.1 (135)	※
44.2 (145)	※

▶定格総荷重

- 定格総荷重とは、水平堅土上における転倒荷重の78%以内で、フックブロック、玉掛用ワイヤロープ等のつり具の質量を含んだ値です。
- 作業半径とはクレーン旋回中心よりつり上荷重の重心までの水平距離を意味します。
- 実際につり上げ得る荷重は定格総荷重から（主フック+玉掛用ワイヤロープ等のつり具）の質量を差し引いた値になります。ただし、中間タワーにブームネスティングローラ（オプション）が取付いた状態で作業する場合の定格荷重の最大値は、使用するフックの呼称容量から使用するフック質量とブームネスティングローラ質量（下表）を差し引いた値とします。

タワー

タワー長さ(m)	30.4	33.4	36.5	39.5	42.5	45.6	48.6	51.7
差し引く値(t)	0.1	0.1	0.1	0.1	0.2	0.2	0.2	0.2

- 定格総荷重をつる場合にも風の影響、地盤の状態、作業速度その他安全作業に有害な状況がある時はオペレータは荷重の軽減、作業速度を遅くするなど状況に応じた判断をする責任があります。
- 表中の空欄の個所では作業を行うことができません。
- クレーン作業中はガントリを最高位置に立ててください。
- すべてのタワー（ジブ）長さにおける中間タワーブーム（ジブ）の構成は取扱説明書の指示を厳守してください。
- ジブ長さ22.9mにてボールフックの使用はできません。
- 51.7mタワーの自立、降下の際にはクローラの前端に敷板（ブロック）を敷いてください。

△ 操作ミスなどによるつり荷の落下を防ぐため、クレーン作業では自由降下（フリーフォール）作業は行わないでください。

- 巻上げロープ巻掛本数に対する最大巻上荷重とフックの質量

フック呼称		35t	ボールフック
最大巻上荷重 (t)	1本掛	12.0	12.0
	2本掛	20.0	—
フック質量		0.90t	0.45t

▶タワー長さ 30.4m

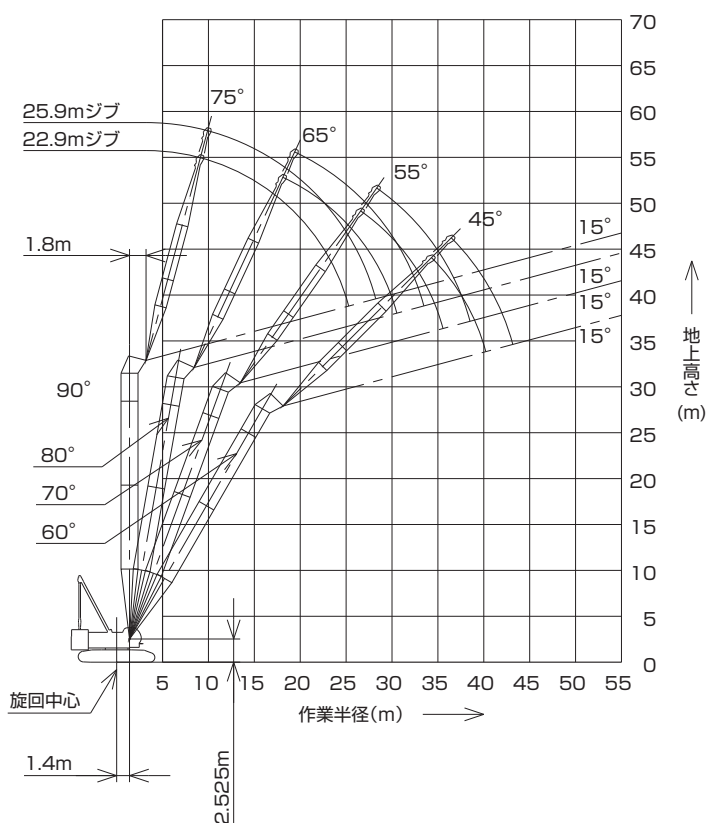

(単位:t)

タワー長さm	30.4								タワー長さm	
ジブ長さm	22.9				25.9				ジブ長さm	
タワー角度	90°	80°	70°	60°	90°	80°	70°	60°	タワー角度	
作業半径(m)	9.4	20.0							9.4	
	10.0	20.0			20.0/10.2m				10.0	
	12.0	20.0			20.0				12.0	
	14.0	20.0			20.0				14.0	
	15.0	20.0			20.0				15.0	
	16.0	18.7			18.7				16.0	
	18.0	16.6	16.3/18.4m		16.6	15.2/19.7m			18.0	
	20.0	15.0	15.0		15.0	15.0			20.0	
	22.0	13.3	13.6		13.6	13.6			22.0	
	24.0	9.9	12.5		12.1	12.5			24.0	
	26.0	7.1/25.4m	11.5	11.1/26.8m	9.5	11.5			26.0	
	28.0		10.7	10.7	6.7	10.7	10.5/28.6m		28.0	
	30.0		10.0	10.0	6.1/28.3m	10.0	10.0		30.0	
	32.0		9.4/30.6m	9.3		9.3	9.3		32.0	
	34.0			8.8	8.6/34.5m		7.7/33.5m	8.8	34.0	
	36.0			8.4/35.6m	8.2			8.3	7.9/36.7m	36.0
	38.0				7.7			7.8	7.6	38.0
40.0				7.2		7.7/38.6m	7.1	40.0		
42.0				7.1/40.3m			6.6	42.0		
44.0							6.4/43.2m	44.0		

※表中の太線で囲まれた部分は、ブーム等の強度によって定められた値です。

※ジブ長さ22.9mでの、ボールフックの使用はできません。

▶タワー長さ 33.4m

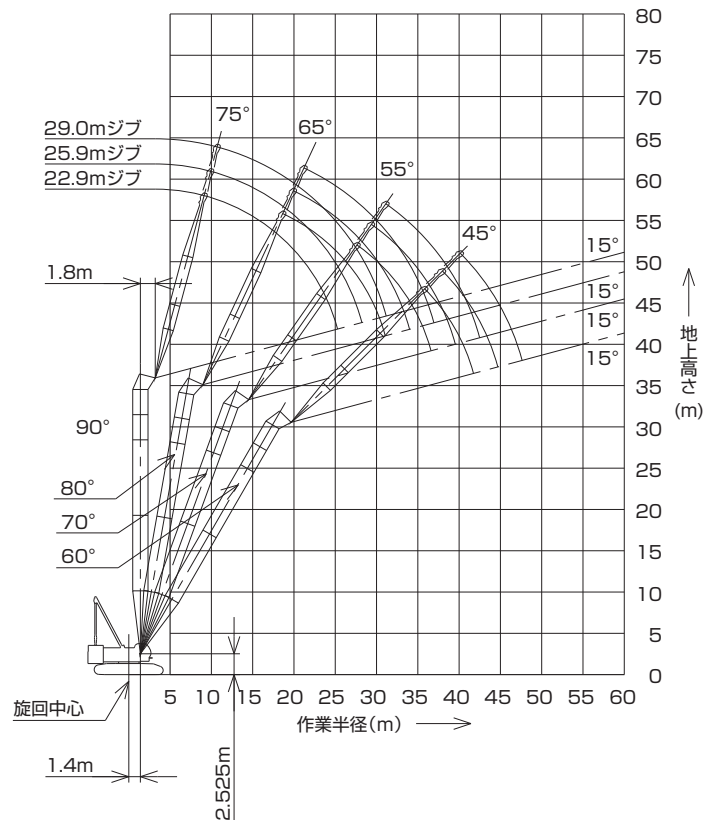

(単位:t)

タワー長さm	33.4												タワー長さm
ジブ長さm	22.9				25.9				29.0				ジブ長さm
タワー角度	90°	80°	70°	60°	90°	80°	70°	60°	90°	80°	70°	60°	タワー角度
作業半径 (m)	9.4	20.0											9.4
	10.0	20.0			20.0/10.2m				20.0/11.0m				10.0
	12.0	20.0			20.0				20.0				12.0
	14.0	20.0			20.0				20.0				14.0
	15.0	20.0			20.0				20.0				15.0
	16.0	18.7			18.7				18.7				16.0
	18.0	16.6	15.8/18.9m		16.6				16.6				18.0
	20.0	15.0	15.0		15.0	14.8/20.2m			15.0	13.9/21.5m			20.0
	22.0	13.4	13.6		13.6	13.6			13.6	13.6			22.0
	24.0	10.0	12.5		12.3	12.5			12.5	12.5			24.0
	26.0	7.2/25.4m	11.5	10.7/27.9m	9.7	11.5			11.2	11.5			26.0
	28.0		10.7	10.7	6.9	10.7	10.1/29.6m		9.1	10.7			28.0
	30.0		10.0	10.0	6.2/28.3m	10.0	10.0		7.0	10.0	9.5/31.4m		30.0
	32.0		9.5/31.1m	9.3		9.3	9.3		5.3/31.2m	9.3	9.3		32.0
	34.0			8.8		8.6	8.8			8.8	8.8		34.0
	36.0			8.3	7.8	8.1/34.1m	8.3			8.3	8.3		36.0
	38.0			8.1/36.7m	7.3		7.8	7.1/38.2m		7.0/37.0m	7.8		38.0
	40.0				6.8		7.5/39.6m	6.7			7.4	6.5/40.3m	40.0
	42.0				6.5/41.8m			6.3			7.1	6.1	42.0
44.0							5.9			6.9/42.6m	5.8	44.0	
46.0							5.8/44.8m				5.4	46.0	
48.0											5.2/47.7m	48.0	

※表中の太線で囲まれた部分は、ブーム等の強度によって定められた値です。
 ※ジブ長さ22.9mでの、ボールフックの使用はできません。

▶タワー長さ 36.5m

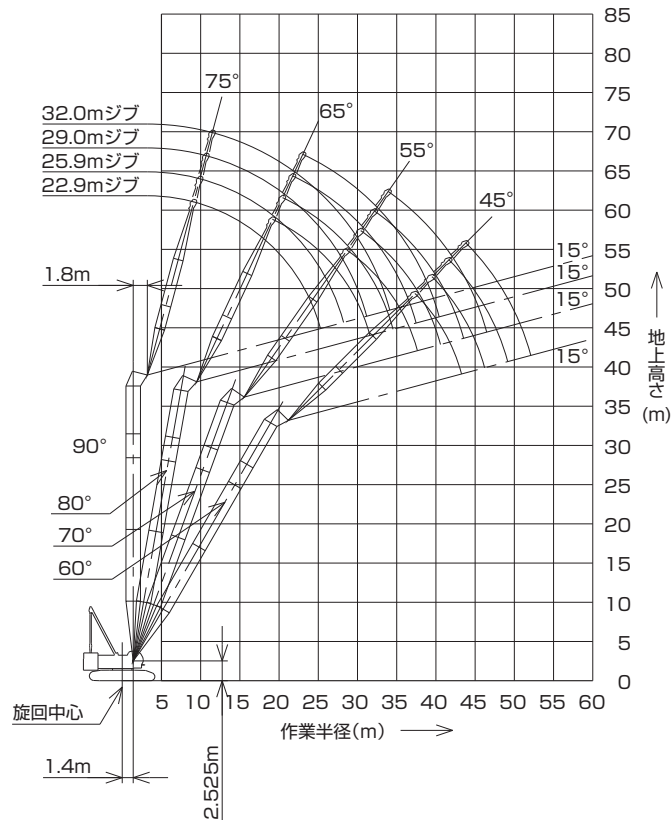

(単位:t)

タワー長さm		36.5																タワー長さm
ジブ長さm		22.9				25.9				29.0				32.0				ジブ長さm
タワー角度		90°	80°	70°	60°	90°	80°	70°	60°	90°	80°	70°	60°	90°	80°	70°	60°	タワー角度
作業半径(m)	9.4	20.0																9.4
	10.0	20.0				20.0/10.2m				20.0/11.0m				20.0/11.8m				10.0
	12.0	20.0				20.0				20.0				20.0				12.0
	14.0	20.0				20.0				20.0				19.6				14.0
	15.0	20.0				20.0				20.0				19.1				15.0
	16.0	18.7				18.7				18.7				18.6				16.0
	18.0	16.6	15.4/19.4m			16.6				16.6				16.6				18.0
	20.0	15.0	15.0			15.0	14.4/20.7m			15.0				15.0				20.0
	22.0	13.5	13.6			13.6	13.6			13.6	13.6			13.6	12.8/23.3m			22.0
	24.0	10.1	12.5			12.4	12.5			12.5	12.5			12.5	12.5			24.0
	26.0	7.3/25.4m	11.5			9.8	11.5			11.2	11.5			11.5	11.5			26.0
	28.0		10.7	10.3/28.9m		6.9	10.7			9.2	10.7			10.2	10.7			28.0
	30.0		10.0	10.0		6.3/28.3m	10.0	9.7/30.7m		7.1	10.0			8.6	10.0			30.0
	32.0		9.4/31.7m	9.3			9.3	9.3		5.4/31.2m	9.3	9.2/32.4m		6.9	9.3			32.0
	34.0			8.8			8.8	8.8			8.8	8.8			8.8	8.7/34.2m		34.0
	36.0			8.3	7.1/37.6m		8.2/34.6m	8.3			8.3	8.3		4.6/34.2m	8.3	8.3		36.0
	38.0			7.9/37.7m	7.0			7.8	6.5/39.7m		7.1/37.6m	7.8			7.8	7.7		38.0
	40.0				6.5			7.4	6.4			7.3	5.9/41.9m		7.0	7.2		40.0
	42.0				6.1			7.3/40.7m	6.0			6.9	5.8		6.2/40.5m	6.8		42.0
	44.0				5.9/43.3m				5.6			6.5/43.6m	5.5			6.4	5.4	44.0
46.0								5.3				5.2			6.0	5.1	46.0	
48.0								5.2/46.3m				4.9			5.9/46.5m	4.8	48.0	
50.0												4.7/49.2m				4.5	50.0	
52.0																4.3	52.0	
54.0																4.2/52.2m	54.0	

※表中の太線で囲まれた部分は、ブーム等の強度によって定められた値です。
 ※ジブ長さ22.9mでの、ボールフックの使用はできません。

▶タワー長さ 39.5m

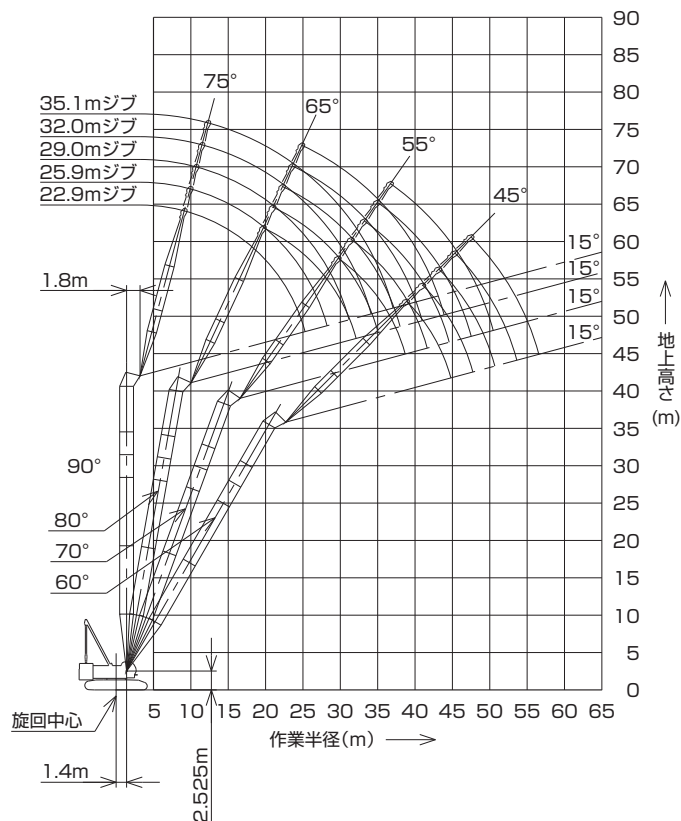

(単位:t)

タワー長さm	39.5																タワー長さm					
ジブ長さm	22.9				25.9				29.0				32.0				35.1				ジブ長さm	
タワー角度	90°	80°	70°	60°	90°	80°	70°	60°	90°	80°	70°	60°	90°	80°	70°	60°	90°	80°	70°	60°	タワー角度	
作業半径 (m)	9.4	20.0																			9.4	
	10.0	20.0			20.0/10.2m				20.0/11.0m				20.0/11.8m								10.0	
	12.0	20.0			20.0				20.0				20.0				16.5/12.5m				12.0	
	14.0	20.0			20.0				20.0				19.6				16.0				14.0	
	15.0	20.0			20.0				20.0				19.1				16.3				15.0	
	16.0	18.7			18.7				18.7				18.6				15.7				16.0	
	18.0	16.6			16.6				16.6				16.6				15.3				18.0	
	20.0	15.0	15.0		15.0	14.1/21.2m			15.0				15.0				14.9				20.0	
	22.0	13.6	13.6		13.6	13.6			13.6	13.3/22.5m			13.6	12.6/23.8m			13.6				22.0	
	24.0	10.2	12.5		12.4	12.5			12.5	12.5			12.5	12.5			12.5	11.9/25.1m			24.0	
	26.0	7.4/25.4m	11.5		9.8	11.5			11.3	11.5			11.5	11.5			11.5	11.5			26.0	
	28.0		10.7		7.0	10.7			9.3	10.7			10.2	10.7			10.7	10.7			28.0	
	30.0		10.0	10.0		6.3/28.3m	10.0	9.4/31.7m		7.2	10.0			8.6	10.0		9.4	10.0			30.0	
	32.0		9.3	9.3			9.3	9.3		5.4/31.2m	9.3	8.9/33.5m		6.9	9.3		8.0	9.3			32.0	
	34.0		9.3/32.2m	8.8			8.8	8.8			8.8	8.7		5.0	8.8	8.2/35.2m		6.7	8.8		34.0	
	36.0			8.3			8.2/35.1m	8.2			8.3	8.1		4.7/34.2m	8.3	8.0		5.2	8.3	7.6/36.9m	36.0	
	38.0			7.8	6.3/39.1m			7.7			7.5	7.5			7.8	7.4		4.1/37.1m	7.8	7.3		38.0
	40.0			7.6/38.8m	6.1			7.2	5.7/41.2m		7.1/38.1m	7.0			7.4	6.9			7.5	6.8		40.0
	42.0				5.8			6.8/41.7m	5.6			6.6	5.2/43.4m		6.2/41.0m	6.5			7.1	6.4		42.0
	44.0				5.4				5.3			6.2	5.1			6.1	4.8/45.5m		5.4	6.0		44.0
46.0				5.3/44.9m				4.9			6.1/44.6m	4.8			5.8	4.7			5.7	4.4/47.7m	46.0	
48.0								4.7/47.8m				4.5			5.5/47.6m	4.4			5.3	4.3	48.0	
50.0												4.3				4.2			5.1	4.1	50.0	
52.0												4.2/50.8m				3.9			5.0/50.5m	3.8	52.0	
54.0																3.7/53.7m				3.6	54.0	
56.0																				3.4	56.0	
58.0																				3.3/56.6m	58.0	

※表中の太線で囲まれた部分は、ブーム等の強度によって定められた値です。
 ※ジブ長さ22.9mでの、ボールフックの使用はできません。

▶タワー長さ 42.5m

(単位:t)

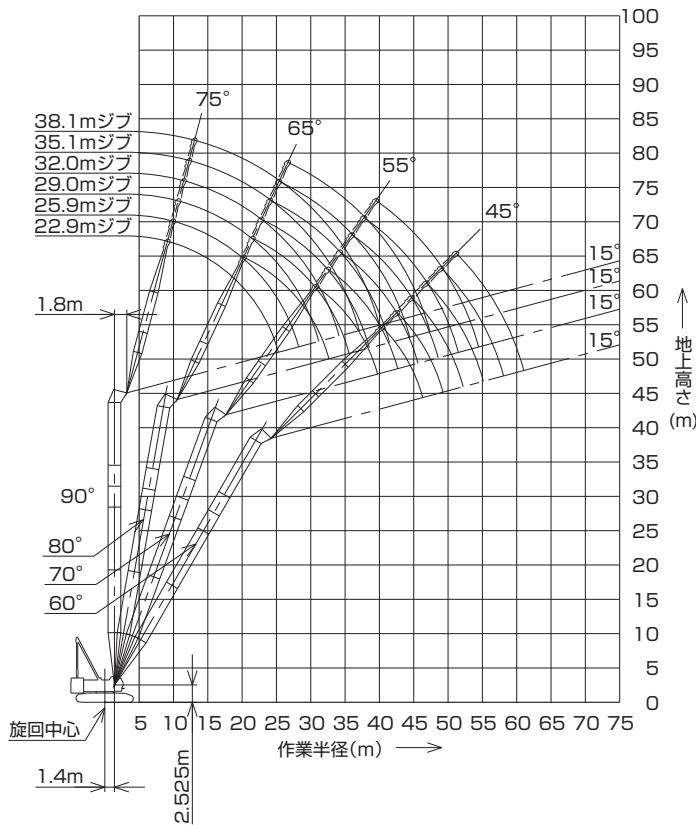

タワー長さm	42.5				タワー長さm
ジブ長さm	22.9				ジブ長さm
タワー角度	90°	80°	70°	60°	タワー角度
9.4	20.0				9.4
10.0	20.0				10.0
12.0	20.0				12.0
14.0	20.0				14.0
15.0	20.0				15.0
16.0	18.7				16.0
18.0	16.6				18.0
20.0	15.0	14.6/20.5m			20.0
22.0	13.6	13.6			22.0
24.0	10.3	12.5			24.0
26.0	7.5/25.4m	11.5			26.0
28.0		10.7			28.0
30.0		10.0	9.6/31.0m		30.0
32.0		9.3	9.3		32.0
34.0		9.1/32.7m	8.7		34.0
36.0			8.1		36.0
38.0			7.5		38.0
40.0			7.1/39.8m	5.7/40.6m	40.0
42.0				5.4	42.0
44.0				5.1	44.0
46.0				4.8	46.0
48.0				4.7/46.4m	48.0
50.0					50.0
52.0					52.0
54.0					54.0
56.0					56.0
58.0					58.0
60.0					60.0

(単位:t)

タワー長さm	42.5																タワー長さm				
ジブ長さm	25.9				29.0				32.0				35.1				38.1				ジブ長さm
タワー角度	90°	80°	70°	60°	90°	80°	70°	60°	90°	80°	70°	60°	90°	80°	70°	60°	90°	80°	70°	60°	タワー角度
10.0	20.0/10.2m				20.0/11.0m				20.0/11.8m												10.0
12.0	20.0				20.0				20.0				16.5/12.5m				13.6/13.3m				12.0
14.0	20.0				20.0				19.5				16.2				13.6				14.0
15.0	20.0				20.0				19.0				16.0				13.4				15.0
16.0	18.7				18.7				18.5				15.7				13.1				16.0
18.0	16.6				16.6				16.6				15.3				12.7				18.0
20.0	15.0	13.7/21.8m			15.0				15.0				14.8				12.3				20.0
22.0	13.6	13.6			13.6	12.9/23.1m			13.6				13.6				11.9				22.0
24.0	12.5	12.5			12.5	12.5			12.5	12.2/24.4m			12.5	11.7/25.6m			11.6				24.0
26.0	9.9	11.5			11.3	11.5			11.5	11.5			11.5	11.5			11.2	11.1/26.9m			26.0
28.0	7.1	10.7			9.3	10.7			10.3	10.7			10.7	10.7			10.5	10.7			28.0
30.0	6.4/28.3m	10.0			7.2	10.0			8.7	10.0			9.4	10.0			9.6	10.0			30.0
32.0		9.3	9.0/32.7m		5.5/31.2m	9.3			7.0	9.3			8.0	9.3			8.5	9.3			32.0
34.0		8.8	8.6		8.8	8.2/34.5m			5.1	8.8			6.7	8.8			7.4	8.8			34.0
36.0		8.2/35.7m	7.9		8.3	7.8			4.7/34.2m	8.3	7.6/36.2m		5.3	8.3			6.3	8.3			36.0
38.0		7.4			7.8	7.3			7.8	7.2			4.1/37.1m	7.8	7.1		5.1	7.8	6.5/39.7m		38.0
40.0		6.9			7.1/38.6m	6.8			7.5	6.7			7.5	6.6			3.7	7.5	6.5		40.0
42.0		6.5	5.1/42.8m		6.4				6.2/41.5m	6.3			7.1	6.2			3.5/40.1m	7.1	6.0		42.0
44.0		6.3/42.7m	4.9		6.0	4.6/44.9m			5.9				6.1	5.8			6.7	5.7			44.0
46.0		4.7			5.7/45.7m	4.5			5.5	4.2/47.1m			5.4/44.5m	5.5			5.9	5.3			46.0
48.0		4.4			4.2				5.2	4.1			5.1	3.8/49.2m			4.7/47.4m	5.0			48.0
50.0		4.2/49.3m			3.9				5.1/48.6m	3.8			4.9	3.7			4.7	4.7	3.3/51.4m		50.0
52.0					3.7				3.7				4.7/51.6m	3.4			4.5	3.2			52.0
54.0					3.7/52.3m				3.3				3.3				4.2	3.0			54.0
56.0										3.2/55.2m				3.0			4.1/54.5m	2.8			56.0
58.0														2.8				2.6			58.0
60.0																	2.8/58.2m	2.5			60.0
62.0																			2.4/61.1m		62.0

※表中の太線で囲まれた部分は、ブーム等の強度によって定められた値です。
 ※ジブ長さ22.9mでの、ボールフックの使用はできません。

▶タワー長さ 45.6m

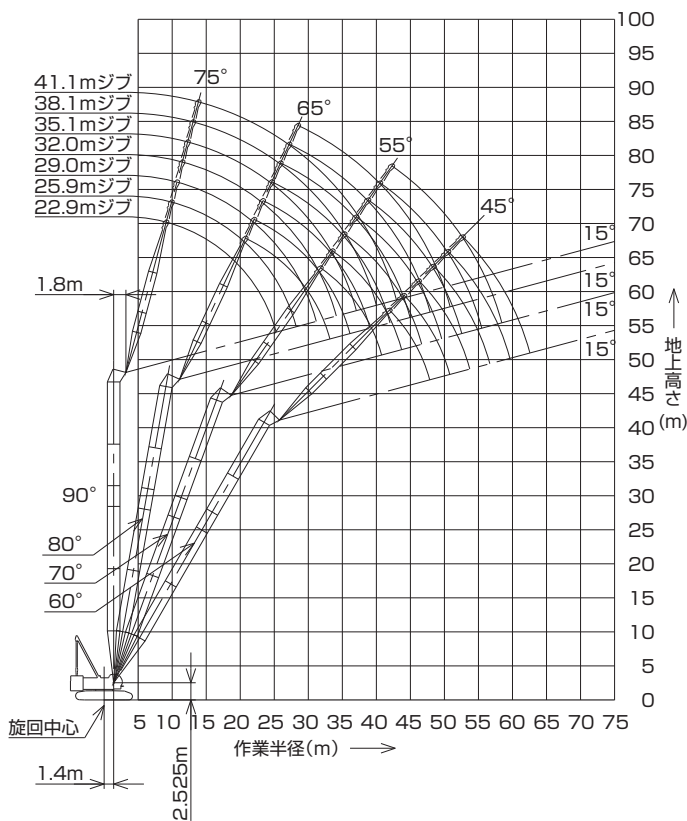

(単位:t)

タワー長さm	45.6								タワー長さm
ジブ長さm	22.9				25.9				ジブ長さm
タワー角度	90°	80°	70°	60°	90°	80°	70°	60°	タワー角度
9.4	20.0								9.4
10.0	20.0				20.0/10.2m				10.0
12.0	20.0				20.0				12.0
14.0	20.0				20.0				14.0
15.0	20.0				20.0				15.0
16.0	18.7				18.7				16.0
18.0	16.6				16.6				18.0
20.0	15.0	14.2/21.0m			15.0				20.0
22.0	13.6	13.6			13.6	13.4/22.3m			22.0
24.0	10.3	12.5			12.5	12.5			24.0
26.0	7.5/25.4m	11.5			9.9	11.5			26.0
28.0		10.7			7.1	10.7			28.0
30.0		10.0			6.4/28.3m	10.0			30.0
32.0		9.3	9.1			9.3	8.3/33.8m		32.0
34.0		9.0/33.2m	8.4			8.8	8.3		34.0
36.0			7.8			8.3	7.7		36.0
38.0			7.3			8.2/36.2m	7.2		38.0
40.0			6.8				6.7		40.0
42.0			6.6/40.8m	5.1/42.1m			6.3		42.0
44.0				4.8			5.9/43.8m	4.5/44.3m	44.0
46.0				4.5				4.3	46.0
48.0				4.2/47.9m				4.0	48.0
50.0								3.7	50.0
52.0								3.6/50.9m	52.0
54.0									54.0
56.0									56.0
58.0									58.0
60.0									60.0

(単位:t)

タワー長さm	45.6																タワー長さm					
ジブ長さm	29.0				32.0				35.1				38.1				41.1				ジブ長さm	
タワー角度	90°	80°	70°	60°	90°	80°	70°	60°	90°	80°	70°	60°	90°	80°	70°	60°	90°	80°	70°	60°	タワー角度	
10.0	20.0/11.0m				20.0/11.8m																	10.0
12.0	20.0				20.0				16.5/12.5m				13.6/13.3m									12.0
14.0	20.0				19.5				16.2				13.6						10.7/14.1m			14.0
15.0	20.0				19.0				16.0				13.3						10.7			15.0
16.0	18.7				18.5				15.7				13.1						10.5			16.0
18.0	16.6				16.6				15.2				12.7						10.2			18.0
20.0	15.0				15.0				14.8				12.3						9.8			20.0
22.0	13.6	12.7/23.6m			13.6				13.6				11.9						9.5			22.0
24.0	12.5	12.5			12.5	12.0/24.9m			12.5				11.6						9.2			24.0
26.0	11.3	11.5			11.5	11.5			11.5	11.4/26.2m			11.1	10.9/27.5m				8.9				26.0
28.0	9.3	10.7			10.3	10.7			10.7	10.7			10.5	10.7				8.6	9.8/28.7m			28.0
30.0	7.2	10.0			8.7	10.0			9.4	10.0			9.6	10.0				8.3	9.6			30.0
32.0	5.5/31.2m	9.3			7.0	9.3			8.1	9.3			8.5	9.3				7.8	9.3			32.0
34.0		8.8	7.6/35.5m		5.2	8.8			6.7	8.8			7.4	8.8				7.3	8.8			34.0
36.0		8.3	7.5		4.8/34.2m	8.3	7.1/37.3m		5.3	8.3			6.3	8.3				6.8	8.3			36.0
38.0		7.8	7.0			7.8	6.9		4.1/37.1m	7.8	6.6/39.0m		5.1	7.8				6.2	7.8			38.0
40.0		7.1/39.1m	6.5			7.5	6.4			7.5	6.3		3.8	7.5	6.0/40.8m			5.2	7.5			40.0
42.0			6.1			6.5	6.0			7.1	5.9		3.5/40.1m	7.1	5.8			4.1	7.1	5.6/42.5m		42.0
44.0			5.8			6.2/42.1m	5.7			6.8	5.6		6.7	5.4				3.2/43.0m	6.6	5.3		44.0
46.0			5.4	4.0/46.4m			5.3			5.4/45.0m	5.2		6.2	5.1				6.2	5.0			46.0
48.0			5.3/46.7m	3.8			5.0	3.6/48.6m		4.9			4.7	4.7				5.8	4.7			48.0
50.0				3.5			4.8/49.7m	3.4		4.7	3.2/50.7m			4.5				5.2	4.4			50.0
52.0				3.3				3.2		4.4	3.0			4.3	2.7/52.9m			4.3/50.9m	4.2			52.0
54.0				3.1/53.8m				3.0		4.3/52.6m	2.8			4.0	2.6				3.9	2.3	2.4/55.1m	54.0
56.0								2.8			2.7			3.9/55.6m	2.5				3.7	2.3		56.0
58.0								2.7/56.7m			2.5				2.4				3.5	2.1		58.0
60.0											2.3/59.7m				2.2				3.5/58.5m	2.0		60.0
62.0																				1.8		62.0
64.0																				1.7		64.0
66.0																				1.6/65.5m		66.0

※表中の太線で囲まれた部分は、ブーム等の強度によって定められた値です。
 ※ジブ長さ22.9mでの、ボールフックの使用はできません。

▶タワー長さ 48.6m

(単位:t)

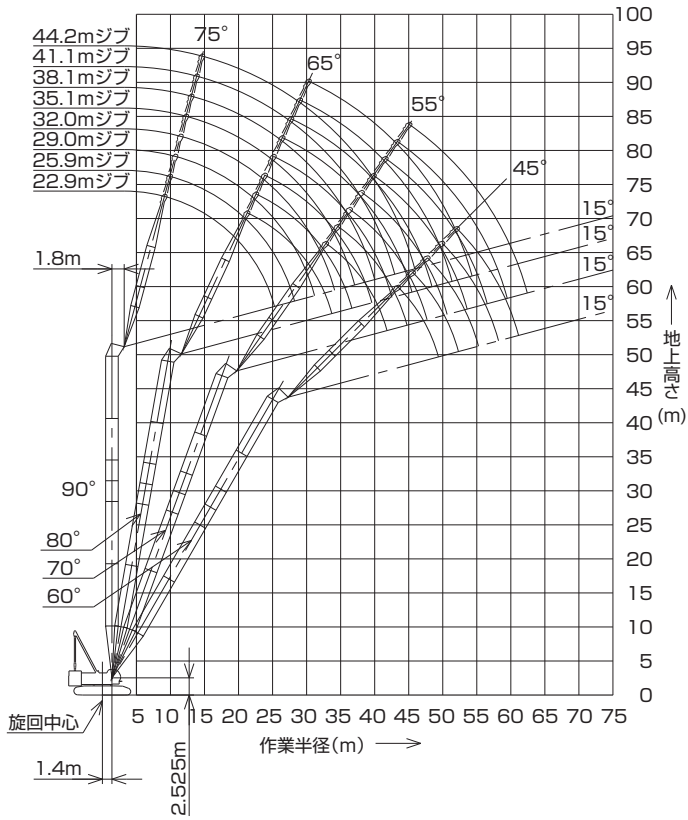

タワー長さm		48.6								タワー長さm
ジブ長さm		22.9				25.9				ジブ長さm
タワー角度		90°	80°	70°	60°	90°	80°	70°	60°	タワー角度
作業半径(m)	9.4	20.0								9.4
	10.0	20.0				20.0/10.2m				10.0
	12.0	20.0				20.0				12.0
	14.0	20.0				20.0				14.0
	15.0	20.0				19.8				15.0
	16.0	18.7				18.7				16.0
	18.0	16.6				16.6				18.0
	20.0	15.0	13.9/21.5m			15.0				20.0
	22.0	13.6	13.6			13.6	13.1/22.8m			22.0
	24.0	10.4	12.5			12.5	12.5			24.0
	26.0	7.5/25.4m	11.5			10.0	11.5			26.0
	28.0		10.7			7.1	10.7			28.0
	30.0		10.0			6.4/28.3m	10.0			30.0
	32.0		9.3	8.3/33.1m			9.3			32.0
	34.0		8.8/33.8m	8.0			8.8	7.6/34.8m		34.0
	36.0			7.5			8.3	7.3		36.0
	38.0			7.0			8.1/36.7m	6.8		38.0
	40.0			6.5				6.4		40.0
	42.0			6.1/41.9m	4.3/43.7m			6.0		42.0
	44.0				4.2			5.6	3.7/45.8m	44.0
46.0				3.9			5.5/44.8m		46.0	
48.0				3.7				3.5	48.0	
50.0				3.5/49.4m				3.2	50.0	
52.0								3.0	52.0	
54.0								2.9/52.4m	54.0	
56.0									56.0	
58.0									58.0	
60.0									60.0	

(単位:t)

タワー長さm		48.6																				タワー長さm				
ジブ長さm		29.0				32.0				35.1				38.1				41.1				44.2				ジブ長さm
タワー角度		90°	80°	70°	60°	90°	80°	70°	60°	90°	80°	70°	60°	90°	80°	70°	60°	90°	80°	70°	60°	90°	80°	70°	タワー角度	
作業半径(m)	10.0	20.0/11.0m				19.9/11.8m																			10.0	
	12.0	20.0				19.9				16.5/12.5m				13.6/13.3m											12.0	
	14.0	19.5				18.6				16.2				13.6				10.7/14.1m					9.1/14.9m		14.0	
	15.0	18.9				18.0				15.9				13.3				10.7					9.1		15.0	
	16.0	18.3				17.5				15.7				13.1				10.5					8.9		16.0	
	18.0	16.6				16.5				15.2				12.7				10.1					8.6		18.0	
	20.0	15.0				15.0				14.8				12.3				9.8					8.3		20.0	
	22.0	13.6				13.6				13.6				11.9				9.5					8.0		22.0	
	24.0	12.5	12.4/24.1m			12.5	11.8/25.4m			12.5				11.5				9.2					7.7		24.0	
	26.0	11.4	11.5			11.5	11.5			11.5	11.2/26.7m			11.1				8.9					7.4		26.0	
	28.0	9.4	10.7			10.3	10.7			10.7	10.7			10.5	10.7			8.6	9.8/29.3m				7.2		28.0	
	30.0	7.3	10.0			8.7	10.0			9.4	10.0			9.6	10.0			8.3	9.6				6.9	8.0/30.6m		30.0
	32.0	6.5/31.2m	9.3			7.1	9.3			8.1	9.3			8.5	9.3			7.8	9.2				6.7	7.8		32.0
	34.0		8.8			5.2	8.8			6.7	8.8			7.4	8.8			7.3	8.8				6.4	7.6		34.0
	36.0		8.3	7.0/36.6m		4.8/34.2m	8.3			5.3	8.3			6.3	8.3			6.8	8.3				6.0	7.3		36.0
	38.0		7.8	6.7		7.8	6.5/38.3m			4.1/37.1m	7.8			5.1	7.8			6.2	7.8				5.6	7.1		38.0
	40.0		7.1/39.7m	6.2		7.3	6.1			7.5	6.0/40.1m			3.8	7.5	5.5/41.8m		5.2	7.3				5.2	6.9		40.0
	42.0			5.8		6.7	5.7			7.1	5.6			3.5/40.1m	6.9	5.5		4.1	6.8	5.1/43.6m			4.8	6.7		42.0
	44.0			5.5		6.2/42.6m	5.4			6.5	5.3				6.5	5.1		3.2/43.0m	6.4	5.0			4.0	6.2	4.7/45.3m	44.0
	46.0			5.1			5.1			6.4/45.6m	5.0				6.0	4.8			5.9	4.7			2.8	5.8	4.6	46.0
48.0			4.9/47.8m	3.2		4.8			4.7					5.5	4.5			5.5	4.4				5.5	4.3	48.0	
50.0				3.0		4.5	2.9/50.1m		4.4					4.7/48.5m	4.3			5.1	4.1			5.1	4.0	50.0		
52.0				2.8		4.4/50.7m	2.7		4.2	2.5/52.3m				4.0				4.3/51.4m	3.9			4.7	3.7	52.0		
54.0				2.6			2.5		4.0/53.7m	2.3				3.8	2.1/54.4m			3.6				4.3	3.5	54.0		
56.0				2.5/55.3m			2.4			2.2				3.6	2.0			3.4	1.8/56.6m			3.8/54.4m	3.3	56.0		
58.0							2.2			2.1				3.5/56.6m	1.8			3.2	1.7				3.1	58.0		
60.0							2.2/58.3m			2.0					1.7			3.1/59.8m	1.5				2.9	60.0		
62.0										1.8/61.2m					1.5				1.4					2.7	62.0	
64.0															1.4									2.6/62.5m	64.0	
66.0															1.4/64.2m										66.0	

※表中の太線で囲まれた部分は、ブーム等の強度によって定められた値です。

※ジブ長さ22.9mでの、ボールフックの使用はできません。

▶タワー長さ 51.7m

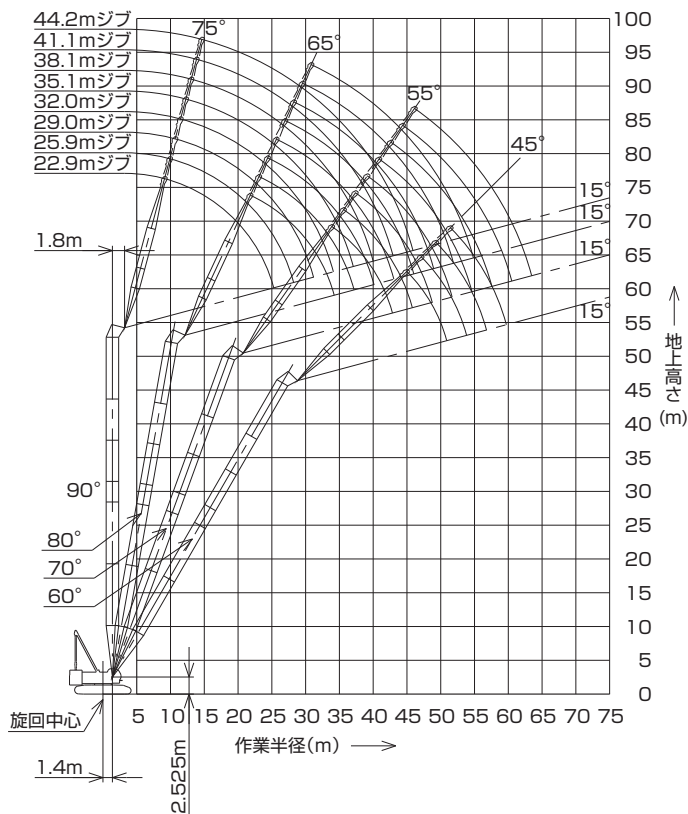

(単位:t)

タワー長さm	51.7								タワー長さm
ジブ長さm	22.9				25.9				ジブ長さm
タワー角度	90°	80°	70°	60°	90°	80°	70°	60°	タワー角度
9.4	20.0								9.4
10.0	20.0				20.0/10.2m				10.0
12.0	20.0				20.0				12.0
14.0	20.0				19.2				14.0
15.0	20.0				18.6				15.0
16.0	18.7				18.1				16.0
18.0	16.6				16.6				18.0
20.0	15.0				15.0				20.0
22.0	13.6	13.5/22.1m			13.6	12.9/23.4m			22.0
24.0	10.4	12.5			12.5	12.5			24.0
26.0	7.6/25.4m	11.5			10.0	11.5			26.0
28.0		10.7			7.2	10.7			28.0
30.0		10.0			28.3m/6.5	10.0			30.0
32.0		9.3				9.3			32.0
34.0		8.8	7.7/34.1m			8.8	7.1/35.9m		34.0
36.0		8.7/34.3m	7.2			8.3	7.0		36.0
38.0			6.7			8.2/37.3m	6.5		38.0
40.0			6.2				6.1		40.0
42.0			5.9				5.7		42.0
44.0			5.7/42.9m	3.6/45.2m			5.4		44.0
46.0				3.5			5.1/45.9m	3.1/47.3m	46.0
48.0				3.2				3.0	48.0
50.0				3.0				2.8	50.0
52.0					2.9/51.0m			2.6	52.0
54.0								2.4/63.9m	54.0
56.0									56.0
58.0									58.0

(単位:t)

タワー長さm	51.7															タワー長さm											
ジブ長さm	29.0				32.0				35.1				38.1			41.1				44.2			ジブ長さm				
タワー角度	90°	80°	70°	60°	90°	80°	70°	60°	90°	80°	70°	60°	90°	80°	70°	90°	80°	70°	90°	80°	70°	90°	80°	70°	タワー角度		
10.0	20.0/11.0m				18.6/11.8m																					10.0	
12.0	19.4				18.6				16.5/12.5m				13.6/13.3m													12.0	
14.0	18.2				17.4				16.2				13.6			10.7/14.1m					9.1/14.9m					14.0	
15.0	17.7				16.8				15.9				13.3			10.7					9.1					15.0	
16.0	17.2				16.4				15.6				13.1			10.5					8.9					16.0	
18.0	16.3				15.5				14.7				12.6			10.1					8.6					18.0	
20.0	15.0				14.7				14.0				12.2			9.8					8.3					20.0	
22.0	13.6				13.6				13.4				11.9			9.5					8.0					22.0	
24.0	12.5	12.1/24.7m			12.5	11.5/25.9m			12.5				11.5			9.1					7.7					24.0	
26.0	11.4	11.5			11.5	11.5			11.5	10.7/27.2m			11.1			8.9					7.4					26.0	
28.0	9.4	10.7			10.3	10.7			10.7	10.3			10.4	10.0/28.5m		8.6	8.5/29.8m			7.1					28.0		
30.0	7.3	10.0			8.7	10.0			9.4	9.9			9.6	9.1		8.3	8.5			6.9	8.0/31.1m					30.0	
32.0	5.5/31.2m	9.3			7.1	9.3			8.1	9.3			8.5	8.8		7.8	8.2			6.7	7.6					32.0	
34.0		8.8			5.2	8.8			6.8	8.8			7.4	8.5		7.3	7.9			6.4	7.3					34.0	
36.0		8.3	6.5/37.6m		4.8/34.2m	8.3			5.3	8.3			6.3	8.2		6.8	7.6			6.0	7.1					36.0	
38.0		7.6	6.4		7.8	6.0/39.4m			4.2/37.1m	7.8			5.2	7.7		6.3	7.4			5.6	6.8					38.0	
40.0		6.9	5.9		7.4	5.8			7.3	5.5/41.1m			3.8	7.1		5.2	7.0			5.2	6.6					40.0	
42.0		6.8/40.2m	5.6		6.8	5.5			6.8	5.4			3.5/40.1m	6.6	5.1/42.9m	4.1	6.5			4.8	6.4					42.0	
44.0		5.2			6.2/43.1m	5.1			6.3	5.0			6.2	4.9	3.2/43.0m	6.1	5.7/44.6m			4.0	5.9					44.0	
46.0		4.9				4.8			5.7	4.7			5.7	4.6		5.7	4.4			2.8	5.5	4.2/46.4m				46.0	
48.0		4.6	2.6/49.5m			4.5			5.4/46.1m	4.4			5.3	4.3		5.3	4.1				5.2	4.0				48.0	
50.0			4.5/48.8m	2.6		4.3	2.3/51.6m			4.2			4.7/49.0m	4.0		4.9	3.8			4.8	3.7					50.0	
52.0				2.5		4.1/51.8m	2.2			3.9	1.9/53.8m			3.7		4.3	3.6			4.5	3.4					52.0	
54.0				2.3			2.1			3.7	1.9			3.5			3.3			4.2	3.2					54.0	
56.0				2.1			2.0			3.6/54.7m	1.8			3.3			3.1			3.8/54.9m	3.0					56.0	
58.0				2.0/56.8m			1.8				1.6				3.1/57.6m		2.9				2.8					58.0	
60.0							1.7/59.8m				1.5						2.8				2.6					60.0	
62.0											1.4						2.7/60.6m				2.5					62.0	
64.0											1.4/62.7m										2.3/63.5m						64.0

*表中の太線で囲まれた部分は、ブーム等の強度によって定められた値です。
*ジブ長さ22.9mでの、ボールフックの使用はできません。

アタッチメント (オプション)

▶ クラムセル (45.1tカウンタウエイト)

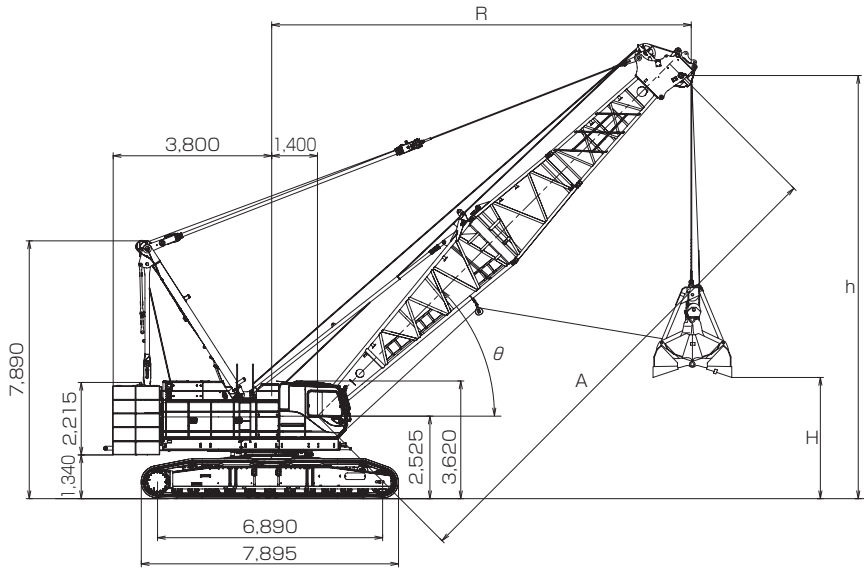

バケット開口時 高さ	バケット容量	2.0m ³	T	3.9m
		2.5m ³		4.3m
		3.0m ³		4.5m
		4.0m ³		4.7m

〈注〉

- ①バケットの単体質量は5.5tを超えてはいけません。
- ②バケットと掘削物の合計質量が定格総荷重を超えてはいけません。
- ③掘削物に応じて、次式により最適なバケットをお選びください。
 $\text{バケット容量 (m}^3\text{)} \times \text{掘削物比重 (t/m}^3\text{)} + \text{バケット質量 (t)} \leq \text{定格荷重 (t)}$
 掘削物：砂、砂利、石灰石等(見掛け比重1~1.5程度)
 例) バケット容量3.0m³、バケット質量5.5tの場合
 $(\text{バケット容量}) \times (\text{掘削物比重}) + (\text{バケット質量}) \leq (\text{定格荷重})$
 $3.0\text{m}^3 \times 1.5 + 5.5\text{t} = 10.0\text{t}$
- ④作業サイクル、バケットの降下高さによってはバケット質量の低減が必要です。
- ⑤定格総荷重は安定度から決まっています。旋回時にブーム横引き荷重が作用するような急加速・急減速は避けてください。特にブームが長いときは注意が必要です。

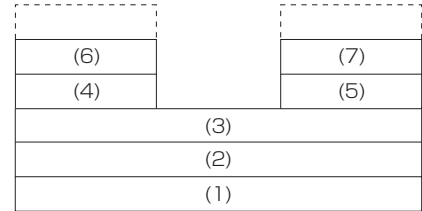

カウンタウエイト

減トン仕様

カウンタウエイト	5段
----------	----

ブーム長さ	m	A	15.2					18.3					21.3					
ブーム角度	度	θ	38	45	55	65	72	40	45	55	65	71	42	45	55	65	68	
作業半径	m	R	14.0	12.8	10.9	8.6	7.0	16.0	15.0	12.6	9.9	8.0	18.0	17.1	14.4	11.2	10.0	
開口地上高さ m	バケット容量	H	2.0m ³	2.6	4.0	5.8	7.2	7.9	7.5	8.7	10.8	12.5	13.3	9.9	10.9	13.3	15.3	15.8
			2.5m ³	2.2	3.6	5.4	6.8	7.5	7.1	8.3	10.4	12.1	12.9	9.5	10.5	12.9	14.9	15.4
			3.0m ³	2.0	3.4	5.2	6.6	7.3	6.9	8.1	10.2	11.9	12.7	9.3	10.3	12.7	14.7	15.2
			4.0m ³	1.8	3.2	5.0	6.4	7.1	6.7	7.9	10.0	11.7	12.5	9.1	10.1	12.5	14.5	15.0
ブームポイント高さ	m	h	11.5	12.9	14.7	16.1	16.8	13.9	15.1	17.2	18.9	19.7	16.3	17.3	19.7	21.7	22.2	
定格総荷重	t		10.0															

ブーム長さ	m	A	24.4					27.4					
ブーム角度	度	θ	43	45	55	65	66	43	45	55	65	69	
作業半径	m	R	20.0	19.3	16.1	12.5	12.0	22.0	21.5	17.9	13.8	12.0	
開口地上高さ m	バケット容量	H	2.0m ³	12.3	13.0	15.8	18.0	18.2	14.6	15.2	18.3	20.8	21.6
			2.5m ³	11.9	12.6	15.4	17.6	17.8	14.2	14.8	17.9	20.4	21.2
			3.0m ³	11.7	12.4	15.2	17.4	17.6	14.0	14.6	17.7	20.2	21.0
			4.0m ³	11.5	12.2	15.0	17.2	17.4	13.8	14.4	17.5	20.0	20.8
ブームポイント高さ	m	h	18.7	19.4	22.2	24.4	24.6	21.0	21.6	24.7	27.2	28.0	
定格総荷重	t		10.0										

台船搭載 (オプション)

主ブーム定格総荷重表

(単位：t)

ブーム長さ 作業半径(m)	15.2	18.3	21.3	24.4	27.4	30.5	33.5	36.6	39.6	ブーム長さ 作業半径(m)
5.0	80.0/5.3m									5.0
6.0	69.1	66.8	63.0/6.7m							6.0
7.0	60.7	60.4	60.1	56.6/7.4m						7.0
8.0	52.7	52.4	52.1		51.2/8.1m	46.7/8.7m				8.0
9.0	46.5	46.3	46.0	45.8	45.5	45.4	41.6/9.4m			9.0
10.0	41.6	41.3	41.0	40.9	40.6	40.4	40.3	37.5/10.1m	33.5/10.8m	10.0
12.0	34.2	33.9	33.6	33.4	33.2	33.0	32.9	32.6	32.2	12.0
14.0	25.0	28.4	28.4	28.2	27.9	27.7	27.5	27.3	27.1	14.0
16.0	21.3/14.9m	22.6	23.8	24.2	23.9	23.8	23.6	23.3	23.1	16.0
18.0		17.7/17.5m	19.4	20.2	20.7	20.7	20.5	20.3	20.1	18.0
20.0			15.1	16.7	17.2	18.2	17.8	17.6	17.5	20.0
22.0			14.8/20.1m	14.0	14.5	15.3	15.7	15.4	15.3	22.0
24.0				12.5/22.8m	12.2	13.1	13.8	13.7	13.6	24.0
26.0					10.5/25.4m	11.2	11.9	12.2	12.1	26.0
28.0						9.5	10.3	10.7	10.9	28.0
30.0							8.8	9.4	9.8	30.0
32.0							8.4/30.7m	8.2	8.6	32.0
34.0								7.4/33.3m	7.5	34.0
36.0									6.6	36.0

〈注〉

- ①作業半径とはクレーンの旋回中心よりつり上荷重の重心までの水平距離を意味します。
- ②定格総荷重は、フックブロック、玉掛用ワイヤロープ等のつり具の重量を含んだ値です。
- ③作業時のクレーン部の傾斜角度は、水平面に対してクレーン前後方向で3°以内、クレーン左右方向で1.5°以内となるようにしてください。定格総荷重はこの条件において設定しています。
- ④上表能力はクローラを固縛した時の能力です。
- ⑤表中の太線で囲まれた部分は、ブーム等の強度によって定められた値です。

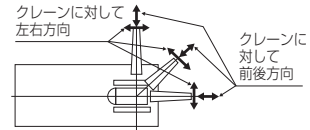

コラムセル作業定格総荷重表

(単位：t)

ブーム長さ 作業半径(m)	15.2	18.3	21.3	24.4	27.4	ブーム長さ 作業半径(m)
8.0	10.0					8.0
9.0	10.0	10.0				9.0
10.0	10.0	10.0	10.0			10.0
12.0	10.0	10.0	10.0	10.0	9.0	12.0
14.0	10.0	10.0	10.0	10.0	9.0	14.0
16.0		10.0	10.0	10.0	9.0	16.0
18.0			10.0	10.0	9.0	18.0
20.0				10.0	9.0	20.0
22.0					9.0	22.0

〈注〉

- ①バケットの単体質量は5.5tを超えてはいけません。
- ②バケットと掘削物の合計質量が定格総荷重を超えてはいけません。
- ③作業半径とは荷重状態におけるクレーンの旋回中心よりバケット重心までの水平距離を意味します。
- ④旋回時にブーム横引き荷重が作用するような急加速・急減速運転、旋回投げ捨ておよび斜め引き掘削等を行わないでください。
- ⑤作業時のクレーン部の傾斜角度は、水平面に対してクレーン前後方向で3°以内、クレーン左右方向で1.5°以内となるようにしてください。定格総荷重はこの条件において設定しています。
- ⑥上表能力はクローラを固縛した時の能力です。

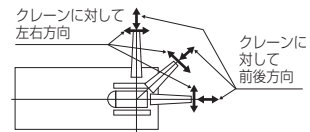

▶分解時の寸法・質量

- 記載の数値は参考値です。
- 一般公道での輸送に際しては関係法規を遵守してください。

■本体

名称	寸法 mm	質量 kg
本体 ・ガントリ ・下部ブーム ・ブームドラム ・クレーンバックストップ ・ワイヤロープ (主巻、補巻、ブーム起伏) 付 ・サイドキャットウォークなし ・クローラなし ・トランスリフタ		36,400
本体 ・ガントリ ・下部ブームなし ・ブームドラム ・クレーンバックストップなし ・ワイヤロープ (主巻、補巻、ブーム起伏) 付 ・サイドキャットウォークなし ・クローラなし ・トランスリフタ		31,700
本体 ・ガントリなし ・下部ブームなし ・ブームドラム ・クレーンバックストップなし ・ワイヤロープなし (主巻、補巻、補巻ドラム) ・サイドキャットウォークなし ・クローラなし ・トランスリフタなし		26,000 ^{※2}

※1 キャブ側にサイドキャットウォークがある場合：3,170
両側にサイドキャットウォークがある場合：3,340

※2 起伏ウインチカプラ (オプション) 他、特殊な治工具が必要です。

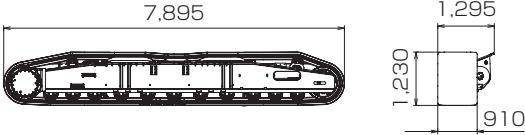
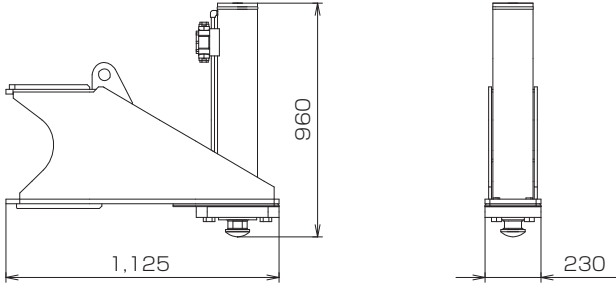
名称	寸法 mm	質量 kg
クローラ	 <p>7,895</p> <p>1,295</p> <p>910</p>	14,600
トランスリフタ (4個)	 <p>960</p> <p>1,125</p> <p>230</p>	265/1個

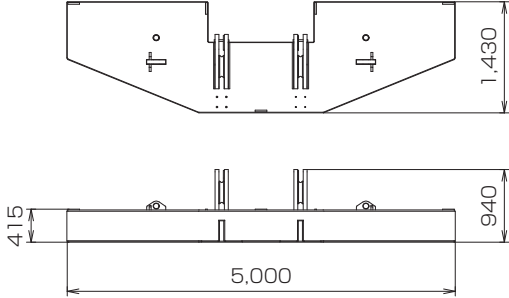
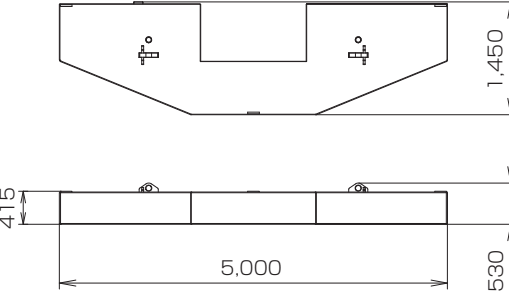
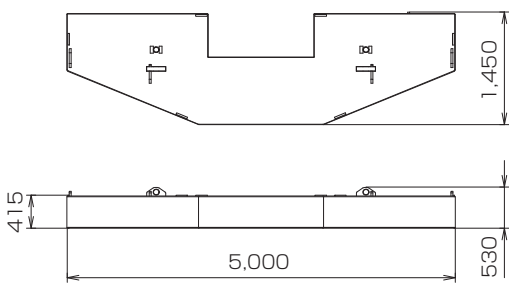
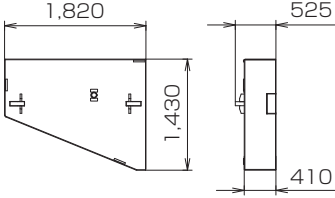
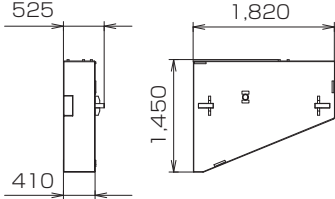
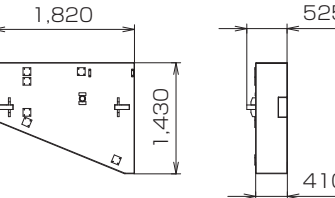
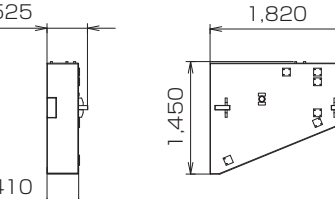
名称	寸法 mm	質量 kg
カウンタウエイト (1)		9,800
カウンタウエイト (2)		9,610
カウンタウエイト (3)		9,700
カウンタウエイト (4)、(6) (L)		4,000
カウンタウエイト (5)、(7) (R)		4,000
カウンタウエイト (8) (L)		4,000
カウンタウエイト (9) (R)		4,000

■アタッチメント（ガイラインの質量は含まれていません）

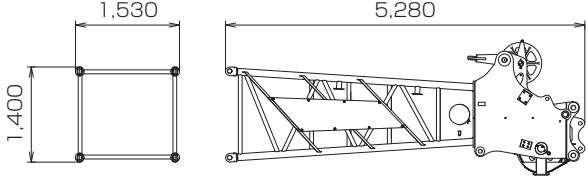
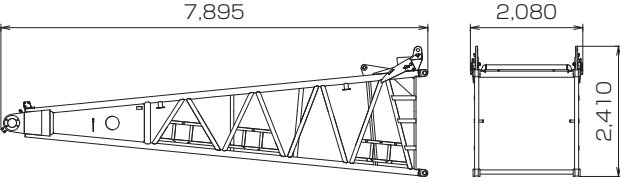
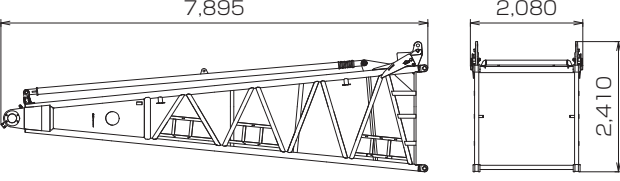
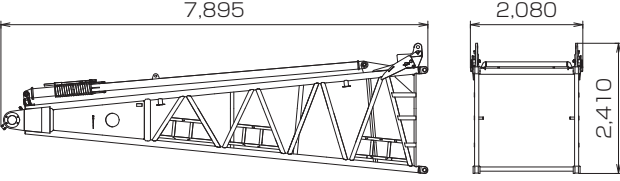
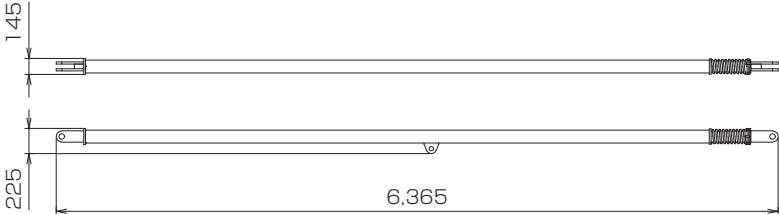
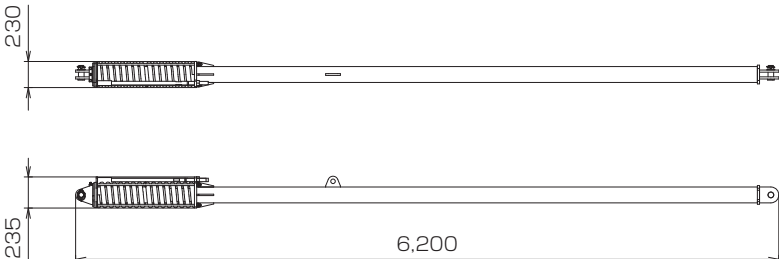
名称	寸法 mm	質量 kg
上部ブーム		1,900
下部ブーム		2,950
クレーンバックストップ付 下部ブーム		3,550
タワーバックストップ付 下部ブーム		3,990
クレーン バックストップ (2個)		210/1個
タワーバックストップ (2個)		420/1個

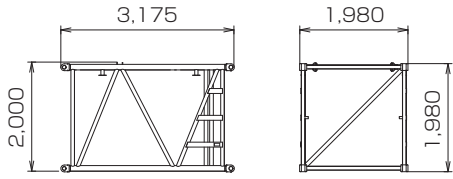
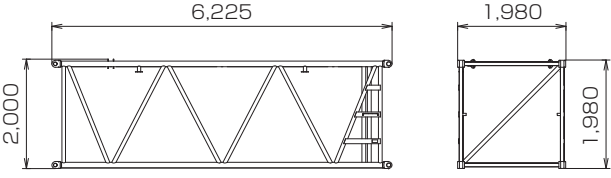
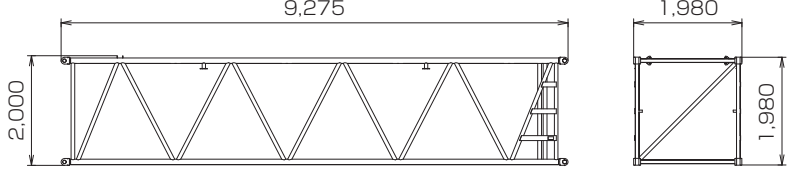
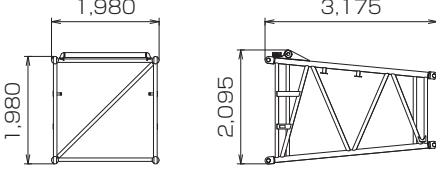
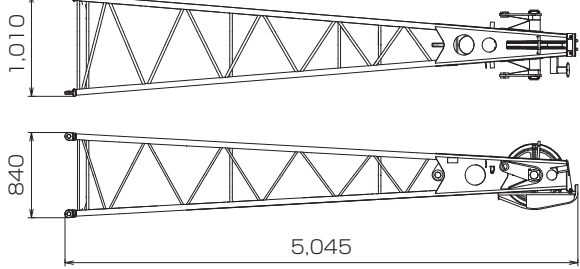
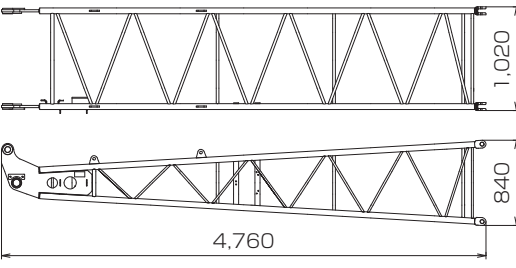
名称	寸法 mm	質量 kg
3.0m中間ブーム		530
6.1m中間ブーム		850
9.1m中間ブーム		1,160
中間テーパブーム		550
上部ジブ		315
下部ジブ		210

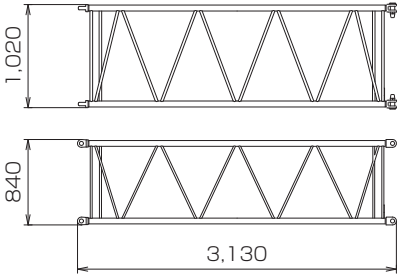
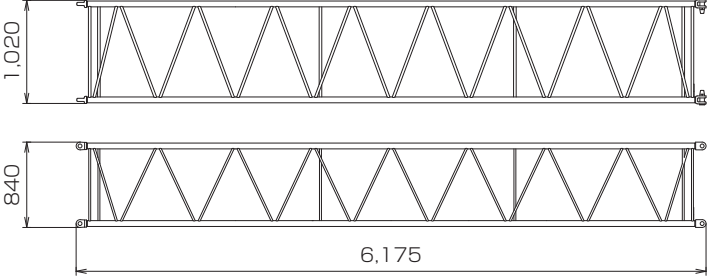
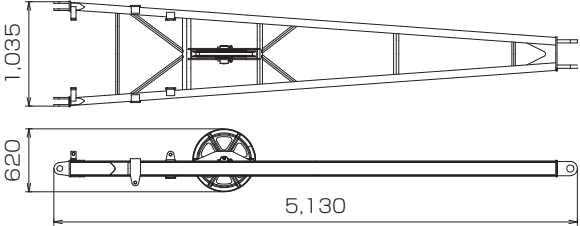
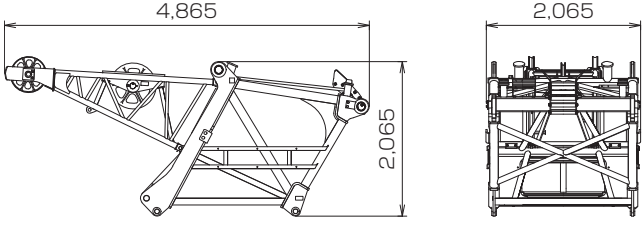
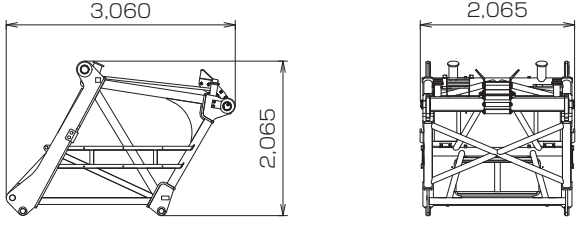
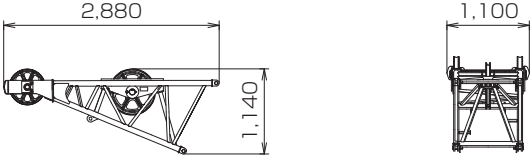
名称	寸法 mm	質量 kg
3.0m中間ジブ		110
6.1m中間ジブ		190
クレーンジブ ストラット		300
ガイドローラ付 タワーキャップ		1,780
タワーキャップ		1,395
ガイドローラ		385

名称	寸法 mm	質量 kg
9.1m 特殊中間タワーブーム (上面足場含む)		2,010
上部タワージブ		860
下部タワージブ		1,200
3.0m中間タワージブ		210
6.1m中間タワージブ		365
9.1m中間タワージブ		515
3.0m 特殊中間タワージブ (特殊中間ブーム)		235

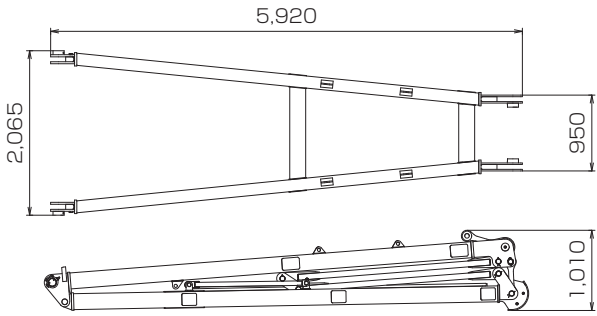
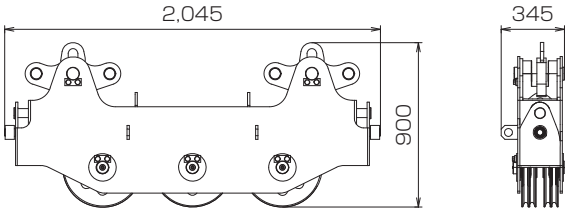
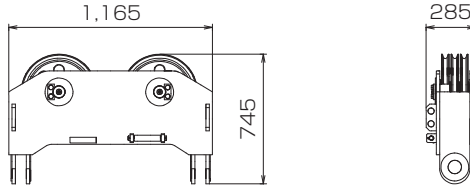
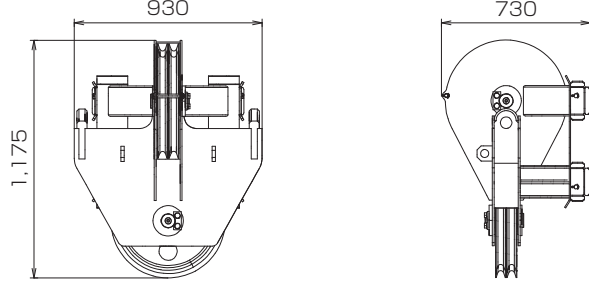
名称	寸法 mm	質量 kg
タワージブストラット		1,390
クレーン用上部スプレッダ		475
クレーン用下部スプレッダ		300
タワー用上部スプレッダ		310

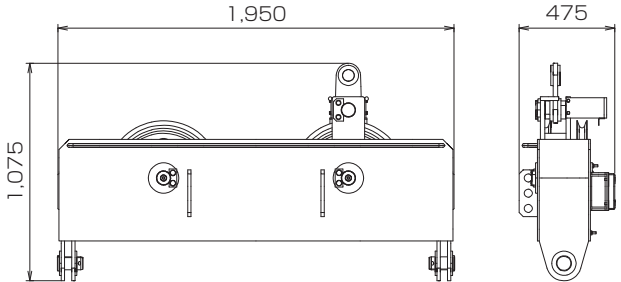
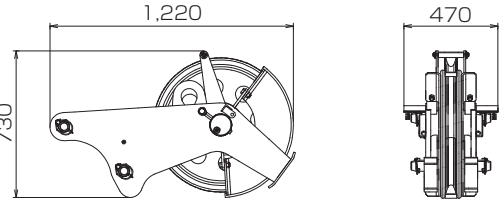
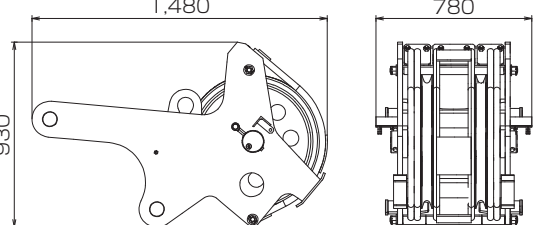
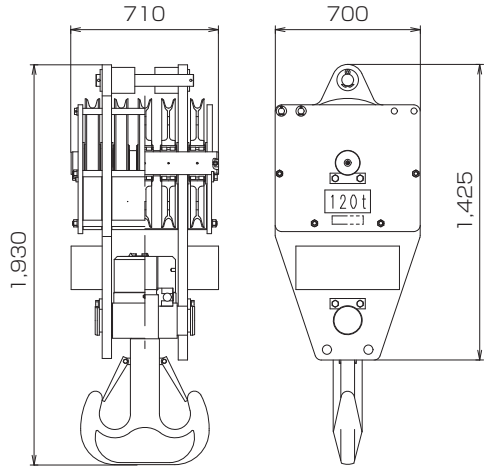
名称	寸法 mm	質量 kg
タワー用下部スプレッド		410
補助シーブ (1枚仕様)		280
補助シーブ (2枚仕様)		550
120tフック		1,700

名称	寸法 mm	質量 kg
70tフック	<p>Technical drawing of a 70t hook. The side view shows a width of 470 mm and a height of 1,825 mm. The front view shows a width of 700 mm and a height of 1,255 mm. The front view also features a '70t' label.</p>	1,200
35tフック	<p>Technical drawing of a 35t hook. The side view shows a width of 460 mm and a height of 1,575 mm. The front view shows a width of 700 mm and a height of 1,135 mm. The front view also features a '35t' label.</p>	900
ボールフック	<p>Technical drawing of a ball hook. The side view shows a diameter of $\phi 380$ mm and a height of 1,205 mm.</p>	450

▶ 標準装備品

●上下部本体
ウインチ(φ26、フリーフォールなし、主巻/補巻)
カウンタウエイト 53.1t
910mm幅シュー
136AH/5HR/バッテリー
トランスリフタ
ガントリ起伏シリンダ
電動ハンドスロットル
ブーム速度可変コントローラ
主補速度可変コントローラ
旋回中立フリー/ブレーキ切替システム
運転席サイドデッキ
右ガード梯子
左ガード昇降ステップ
クローラ昇降ステップ
アンチスリップシート(ガード上面)
上部スプレッド自動格納装置
標準工具一式
工具箱
別置工具箱
前照灯×2
バックミラー×2
ドラムミラー
ワンウェイコイル
水準器(カーボディ)
ブームコネクティブホルダ
●運転室
エアコン
カップキーパ

ラジオ(FM/AM)
シガーライタ
間欠式ワイパ&ウインドウウォッシャ(天窓/前面)
サンバイザ
天井ブラインド
グリーンガラス
フロアマット(布製)
靴置きトレイ
●安全装置
過負荷防止装置(ブーム巻下緩停止機能付)
解除スイッチマスターキー
マルチディスプレイ
第2過巻防止装置(ブーム角度極限停止機能)
ブーム過巻自動停止装置(緩停止機能付)
フック過巻自動停止装置
ブームバックストップ
乗降遮断式レバーロック
操作レバーロック(走行/主巻/補巻/ブーム起伏)
ケーブル式ドラムパウル(主巻/補巻/ブーム起伏)
中立時ネガブレーキ(主巻/補巻/ブーム起伏/走行)
旋回中立フリー/ブレーキ切替表示灯
旋回中立フリー/ブレーキ切替スイッチ
油圧安全弁(主巻/補巻/ブーム起伏/走行)
ホーン
旋回ブレーキロック
旋回ロック
旋回フラッシュ/ブザー
エンジン緊急停止スイッチ

▶ オプション装備品

トラベルキット
ウインチ(φ26、フリーフォール付、主巻/補巻)
サードドラム(φ26、フリーフォール付)
リーピングウインチ(ワイヤロープφ8)
油圧式タグライン
ガイケーブル格納ブラケット
減トン仕様(カウンタウエイト枚数検出装置付)
台船搭載用ML
ブームネスティングローラ
自立用敷板
フットアクセル
ブーム起伏ベダル
揚程・深度表示装置
ドラム回転感知レバー
本体傾斜計
旋回制限装置
水準器(キャブ内)
キャブ天井ガード
サイドキャットウォーク(手すり付)
左右ガード上面手すり
カウンタウエイト上面手すり
定格総荷重表銘板(下部ブーム腹面)
後方監視カメラ
主補ドラム監視カメラ
ブームドラム監視カメラ
ドラムライト

過負荷外部表示灯(角型3色灯)
風速計
航空障害灯
中立フリー/過負荷ボイスアラーム
走行/旋回ボイスアラーム
電動式燃料給油ポンプ
消火器
扇風機
後方作業灯
防塵ネット(右ガード後部)
キャブ前方追加ライト(キャブ左上部)
ベバスト燃焼式ヒータ
寒冷地対策オプション
主補コントロールレバー入替
油圧式ブームフットピン
キャブ左窓ガラス用ガードプレート
カウンタウエイト・クローラつりワイヤロープ
上部ブーム腹面保護材
ロング上部ブーム腹面保護材
中間ブーム梯子
ブームつり用ナイロンスリング
タワーラッチ監視カメラ
ワイヤ脱落防止ガイド
ブーム上面足場(鉄/アルミ)
ブーム上面手すり(1本物/親綱式)
ブームつりピース







つり上げ荷重5t以上の移動式クレーン運転には「移動式クレーン運転士免許証」、クラムセル作業には「車両系建設機械(整地ほか)運転技能講習修了証」、基礎工事には「車両系建設機械(基礎用)運転技能講習修了証」がそれぞれ必要です。

コベルコ建機株式会社

www.kobelco-kenki.co.jp

東京本社 / 〒141-8626 東京都品川区北品川5-5-15 ☎03-5789-2111

北海道 ☎011-788-2386・宮城 ☎0223-24-1482・横浜 ☎045-834-9992

北陸 ☎076-274-1218・東海 ☎052-603-1205・近畿 ☎06-6414-2103

中国 ☎082-810-3880・九州 ☎092-410-3035

■お問い合わせは……

適用型式:7120G-2

7120G-2SPEC-3(仕様はお断りせずに変更することがありますのでご了承ください。)170901F
本機のご使用にあたっては取扱説明書を必ずお読み下さい。

